

# Engineering Data

## Four-way Cassette VRF IDU



MI2-28Q4DHN1

MI2-80Q4DHN1

MI2-36Q4DHN1

MI2-90Q4DHN1

MI2-45Q4DHN1

MI2-100Q4DHN1

MI2-56Q4DHN1

MI2-112Q4DHN1

MI2-71Q4DHN1

MI2-140Q4DHN1

# Four-way Cassette

<b>1 Specifications .....</b>	<b>4</b>
<b>2 Dimensions .....</b>	<b>8</b>
<b>3 Unit Placement .....</b>	<b>9</b>
<b>4 Piping Diagram .....</b>	<b>11</b>
<b>5 Wiring Diagram .....</b>	<b>12</b>
<b>6 Capacity Tables.....</b>	<b>15</b>
<b>7 Electrical Characteristics.....</b>	<b>16</b>
<b>8 Sound Levels .....</b>	<b>17</b>
<b>9 Temperature and Airflow Distributions .....</b>	<b>19</b>

## 1 Specifications

### MI2-28Q4DHN1 / MI2-36Q4DHN1 / MI2-45Q4DHN1

Table 1.1: MI2-28(36, 45)Q4DHN1 specifications

Model			MI2-28Q4DHN1	MI2-36Q4DHN1	MI2-45Q4DHN1	
Power supply			1 phase, 220-240V, 50/60Hz			
Cooling <sup>1</sup>	Capacity	kW	2.8	3.6	4.5	
		kBtu/h	9.6	12.3	15.4	
	Power input	W	40	45	50	
Heating <sup>2</sup>	Capacity	kW	3.2	4.0	5.0	
		kBtu/h	10.9	13.6	17.1	
	Power input	W	40	45	50	
Fan motor	Type	DC motor				
	Number	1				
Indoor coil	Number of rows		1		2	
	Tube pitch × row pitch	mm	21×13.37			
	Fin spacing	mm	1.5			
	Fin type		Hydrophilic aluminum			
	Tube OD and type	mm	Φ7 Inner-groove			
	Dimensions (L×H×W)	mm	1930×168×13.37		1961×168×26.74	
	Number of circuits		4		8	
Air flow rate <sup>3</sup>		m <sup>3</sup> /h	801/751/711/658/637/611/542		893/866/804/744/714/698/635	
Sound pressure level <sup>4</sup>		dB(A)	32/31/30/28/28/26/23		35/34/31/31/30/28/26	
Main body	Net dimensions <sup>5</sup> (W×H×D)		mm 840×230×840			
	Packed dimensions (W×H×D)		mm 955×260×955			
	Net/Gross weight		kg 21.3/25.8		23.2/27.6	
Panel	Net dimensions (W×H×D)		mm 950×54.5×950			
	Packed dimensions (W×H×D)		mm 1035×90×1035			
	Net/Gross weight		kg 5.5/8.2			
Refrigerant type			R410A			
Design pressure (H/L)		MPa	4.4/2.6			
Pipe connections	Liquid/Gas pipe		mm Φ6.35/Φ12.7			
	Drain pipe		mm OD Φ32			

Notes:

- Indoor temperature 27°C DB, 19°C WB; outdoor temperature 35°C DB; equivalent refrigerant piping length 7.5m with zero level difference.
- Indoor temperature 20°C DB; outdoor temperature 7°C DB, 6°C WB; equivalent refrigerant piping length 7.5m with zero level difference.
- Air flow rate are from the highest speed to the lowest speed, total 7 rates for each model.
- Sound pressure level is from highest level to lowest level, total 7 levels for each model. Sound pressure level is measured 1.4m below the unit in a semi-anechoic chamber.
- Unit body dimensions given are the largest external dimensions of the unit, including hanger attachments.

## MI2-56Q4DHN1 / MI2-71Q4DHN1 / MI2-80Q4DHN1

Table 1.2: MI2-56(71, 80)Q4DHN1 specifications

Model			MI2-56Q4DHN1	MI2-71Q4DHN1	MI2-80Q4DHN1
Power supply			1 phase, 220-240V, 50/60Hz		
Cooling <sup>1</sup>	Capacity	kW	5.6	7.1	8.0
		kBtu/h	19.1	24.2	27.3
	Power input	W	60	70	96
Heating <sup>2</sup>	Capacity	kW	6.3	8.0	9.0
		kBtu/h	21.5	27.3	30.7
	Power input	W	60	70	96
Fan motor	Type		DC motor		
	Number		1		
Indoor coil	Number of rows		2		
	Tube pitch × row pitch	mm	21×13.37		
	Fin spacing	mm	1.5		
	Fin type		Hydrophilic aluminum		
	Tube OD and type	mm	Φ7 Inner-groove		
	Dimensions (L×H×W)	mm	1961×168×26.74		
	Number of circuits		8		
Air flow rate <sup>3</sup>		m <sup>3</sup> /h	893/866/804/744/714/ 698/635	977/937/864/800/778/ 738/671	1203/1131/1064/977/9 12/840/774
Sound pressure level <sup>4</sup>		dB(A)	35/34/31/31/30/28/26	35/35/34/31/30/28/27	36/35/34/31/31/29/28
Main body	Net dimensions <sup>5</sup> (W×H×D)		mm 840×230×840		
	Packed dimensions (W×H×D)		mm 955×260×955		
	Net/Gross weight		kg 23.2/27.6		
Panel	Net dimensions (W×H×D)		mm 950×54.5×950		
	Packed dimensions (W×H×D)		mm 1035×90×1035		
	Net/Gross weight		kg 5.5/8.2		
Refrigerant type			R410A		
Design pressure (H/L)		MPa	4.4/2.6		
Pipe connections	Liquid/Gas pipe		mm Φ9.53/Φ15.9		
	Drain pipe		mm OD Φ32		

Notes:

- Indoor temperature 27°C DB, 19°C WB; outdoor temperature 35°C DB; equivalent refrigerant piping length 7.5m with zero level difference.
- Indoor temperature 20°C DB; outdoor temperature 7°C DB, 6°C WB; equivalent refrigerant piping length 7.5m with zero level difference.
- Air flow rate are from the highest speed to the lowest speed, total 7 rates for each model.
- Sound pressure level is from highest level to lowest level, total 7 levels for each model. Sound pressure level is measured 1.4m below the unit in a semi-anechoic chamber.
- Unit body dimensions given are the largest external dimensions of the unit, including hanger attachments.

# The 2<sup>nd</sup> Generation DC Series VRF Indoor Units



## MI2-90Q4DHN1 / MI2-100Q4DHN1

Table 1.3: MI2-90(100)Q4DHN1 specifications

Model			MI2-90Q4DHN1	MI2-100Q4DHN1	
Power supply			1 phase, 220-240V, 50/60Hz		
Cooling <sup>1</sup>	Capacity	kW	9.0	10.0	
		kBtu/h	30.7	34.1	
	Power input	W	100	150	
Heating <sup>2</sup>	Capacity	kW	10.0	11.0	
		kBtu/h	34.1	37.5	
	Power input	W	100	150	
Fan motor	Type	DC motor			
	Number	1			
Indoor coil	Number of rows		2	2	
	Tube pitch × row pitch	mm	21×13.37		
	Fin spacing	mm	1.5		
	Fin type		Hydrophilic aluminum		
	Tube OD and type	mm	Φ7 Inner-groove		
	Dimensions (L×H×W)	mm	1955×252×26.74		
	Number of circuits		12		
Air flow rate <sup>3</sup>		m <sup>3</sup> /h	1349/1294/1230/1201/1111/1029/970	1700/1600/1440/1250/1200/1150/1100	
Sound pressure level <sup>4</sup>		dB(A)	37/35/34/31/31/30/28	43/42/40/38/37/35/34	
Main body	Net dimensions <sup>5</sup> (W×H×D)		mm 840×300×840		
	Packed dimensions (W×H×D)		mm 955×330×955		
	Net/Gross weight		kg 28.4/33.8		
Panel	Net dimensions (W×H×D)		mm 950×54.5×950		
	Packed dimensions (W×H×D)		mm 1035×90×1035		
	Net/Gross weight		kg 5.5/8.2		
Refrigerant type			R410A		
Design pressure (H/L)		MPa	4.4/2.6		
Pipe connections	Liquid/Gas pipe		mm Φ9.53/Φ15.9		
	Drain pipe		mm OD Φ32		

Notes:

- Indoor temperature 27°C DB, 19°C WB; outdoor temperature 35°C DB; equivalent refrigerant piping length 7.5m with zero level difference.
- Indoor temperature 20°C DB; outdoor temperature 7°C DB, 6°C WB; equivalent refrigerant piping length 7.5m with zero level difference.
- Air flow rate are from the highest speed to the lowest speed, total 7 rates for each model.
- Sound pressure level is from highest level to lowest level, total 7 levels for each model. Sound pressure level is measured 1.4m below the unit in a semi-anechoic chamber.
- Unit body dimensions given are the largest external dimensions of the unit, including hanger attachments.

## MI2-112Q4DHN1 / MI2-140Q4DHN1

Table 1.4: MI2-112(140)Q4DHN1 specifications

Model			MI2-112Q4DHN1	MI2-140Q4DHN1	
Power supply			1 phase, 220-240V, 50/60Hz		
Cooling <sup>1</sup>	Capacity	kW	11.2	14.0	
		kBtu/h	38.2	47.8	
	Power input	W	160	170	
Heating <sup>2</sup>	Capacity	kW	12.5	16.0	
		kBtu/h	42.7	54.6	
	Power input	W	160	170	
Fan motor	Type	DC motor			
	Number	1			
Indoor coil	Number of rows		2	3	
	Tube pitch × row pitch	mm	21×13.37		
	Fin spacing	mm	1.5		
	Fin type		Hydrophilic aluminum		
	Tube OD and type	mm	Φ7 Inner-groove		
	Dimensions (L×H×W)	mm	1955×252×26.74	1955×252×40.11	
	Number of circuits		12	12	
Air flow rate <sup>3</sup>		m <sup>3</sup> /h	1700/1600/1440/1250/1200/1150/1100	1800/1650/1500/1300/1250/1200/1150	
Sound pressure level <sup>4</sup>		dB(A)	43/42/40/38/37/35/34	45/44/42/41/40/39/37	
Main body	Net dimensions <sup>5</sup> (W×H×D)		840×300×840		
	Packed dimensions (W×H×D)		955×330×955		
	Net/Gross weight		28.4/33.8	30.7/35.8	
Panel	Net dimensions (W×H×D)		950×54.5×950		
	Packed dimensions (W×H×D)		1035×90×1035		
	Net/Gross weight		5.5/8.2		
Refrigerant type			R410A		
Design pressure (H/L)		MPa	4.4/2.6		
Pipe connections	Liquid/Gas pipe		Φ9.53/Φ15.9		
	Drain pipe		OD Φ32		

Notes:

- Indoor temperature 27°C DB, 19°C WB; outdoor temperature 35°C DB; equivalent refrigerant piping length 7.5m with zero level difference.
- Indoor temperature 20°C DB; outdoor temperature 7°C DB, 6°C WB; equivalent refrigerant piping length 7.5m with zero level difference.
- Air flow rate are from the highest speed to the lowest speed, total 7 rates for each model.
- Sound pressure level is from highest level to lowest level, total 7 levels for each model. Sound pressure level is measured 1.4m below the unit in a semi-anechoic chamber.
- Unit body dimensions given are the largest external dimensions of the unit, including hanger attachments.

## 2 Dimensions

### 2.1 Unit Dimensions

Figure 2.1: Four-way Cassette dimensions (unit: mm)

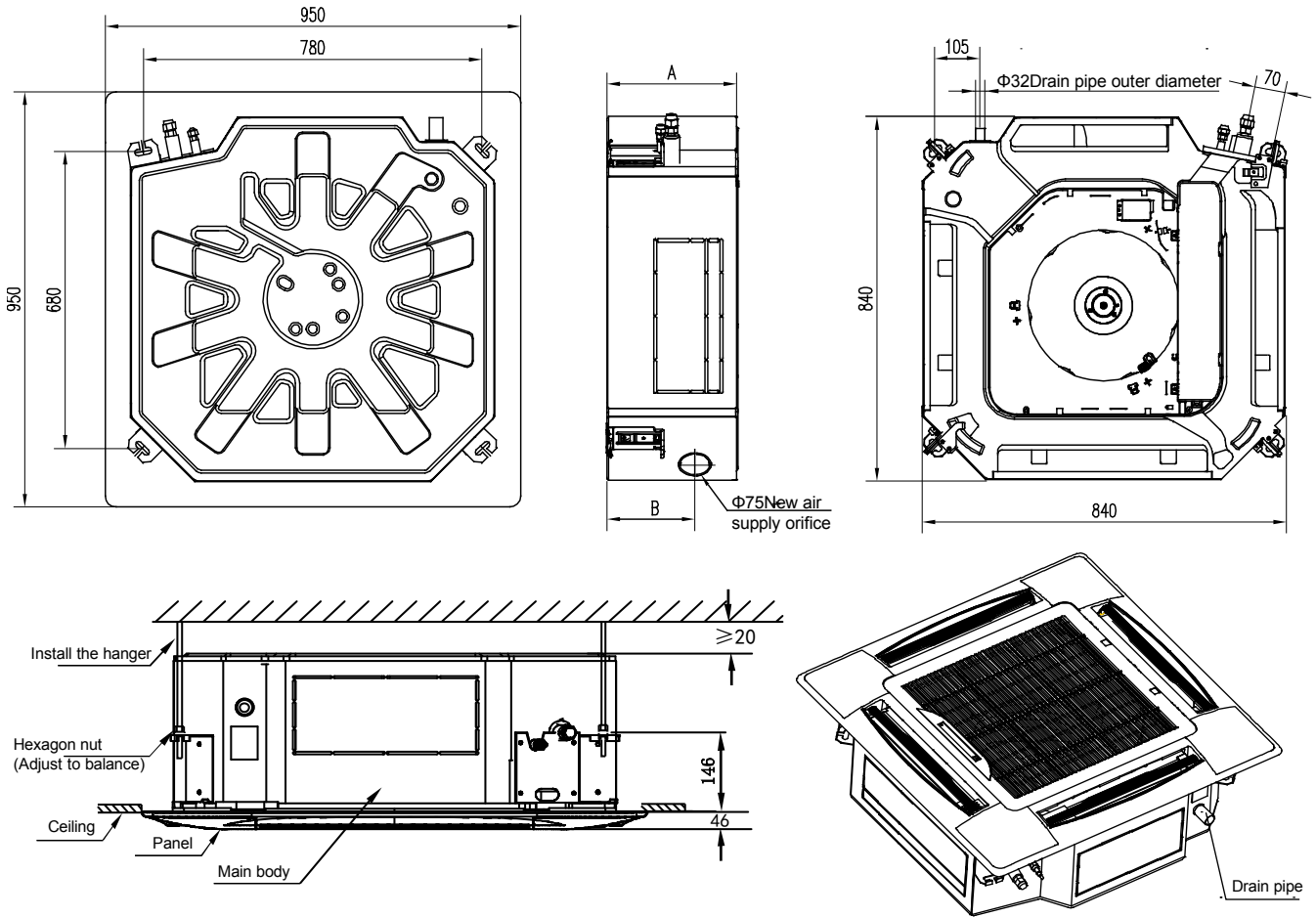

Table 2.1: Four-way Cassette dimensions

Model names	Dimensions (mm)	
	A	B
MI2-28Q4DHN1 MI2-36Q4DHN1 MI2-45Q4DHN1 MI2-56Q4DHN1 MI2-71Q4DHN1 MI2-80Q4DHN1	230	126
MI2-90Q4DHN1 MI2-100Q4DHN1 MI2-112Q4DHN1 MI2-140Q4DHN1	300	197

Table 2.2: Four-way Cassette piping connections

Model names	Gas pipe (mm)	Liquid pipe (mm)
MI2-28Q4DHN1 MI2-36Q4DHN1 MI2-45Q4DHN1	Φ12.7	Φ6.35
MI2-56Q4DHN1 MI2-71Q4DHN1 MI2-80Q4DHN1 MI2-90Q4DHN1 MI2-100Q4DHN1 MI2-112Q4DHN1 MI2-140Q4DHN1	Φ15.9	Φ9.53

## 3 Unit Placement

### 3.1 Placement Considerations

Unit placement should take account of the following considerations:

- Units should not be installed in the following locations:
  - Where exposure to direct radiation from a high-temperature heat source or to interference from a source of electromagnetic radiation may occur.
  - Where dust or dirt may affect heat exchangers.
  - Where exposure to oil or to corrosive or harmful gases, such as acidic or alkaline gases, may occur.
  - Where exposure to salinity may occur, such as seaside locations.
  - Where highly flammable materials are present.
  - Where exposure to oily air may occur, such as a kitchen.
  - Where exposure to very high humidity may occur, such as a laundry.
- Units should be installed in positions where:
  - The ceiling is horizontal and is able to bear the unit's weight.
  - There are no obstructions that could impede the airflow into and out of the unit.
  - The airflow out of the unit can reach throughout the room.
  - There is sufficient space for access during installation, servicing and maintenance.
  - The refrigerant piping and drain piping can be easily connected to the refrigerant piping and drain piping systems.
  - Short-circuit ventilation (where outlet air returns quickly to a unit's air inlet) will not occur.

### 3.2 Space Requirements

Figure 3.1: Four-way Cassette space requirements (unit: mm)

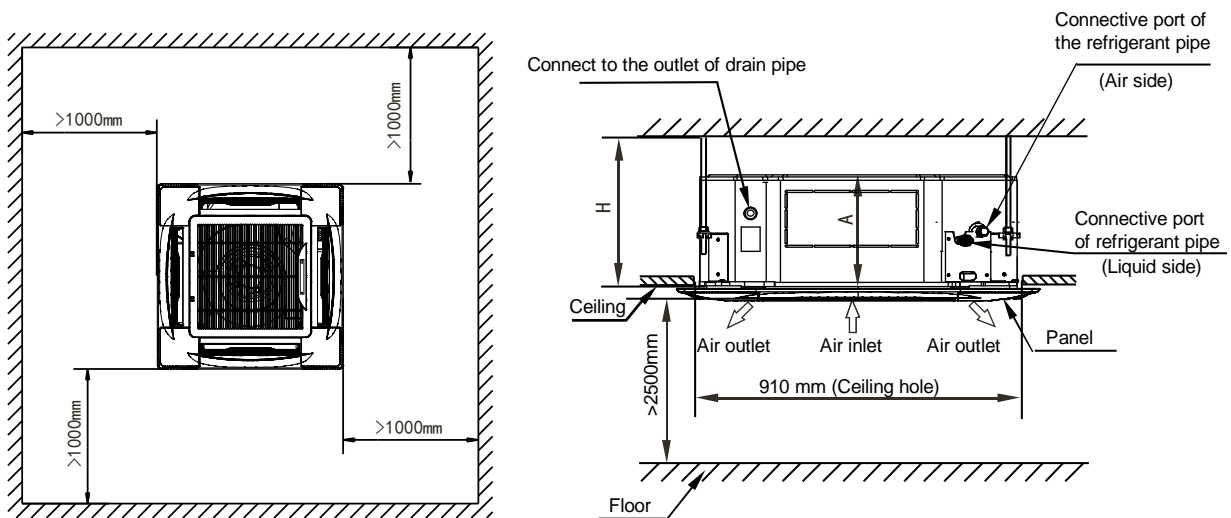



The 2<sup>nd</sup> Generation DC Series VRF Indoor Units

Table 3.1: Four-way Cassette dimensions and space requirements

Model name	Dimensions / Requirements (mm)	
	A	H
MI2-28Q4DHN1 MI2-36Q4DHN1 MI2-45Q4DHN1 MI2-56Q4DHN1 MI2-71Q4DHN1 MI2-80Q4DHN1	230	≥260
MI2-90Q4DHN1 MI2-100Q4DHN1 MI2-112Q4DHN1 MI2-140Q4DHN1	300	≥330

### 4 Piping Diagram

Figure 4.1: Four-way Cassette piping diagram

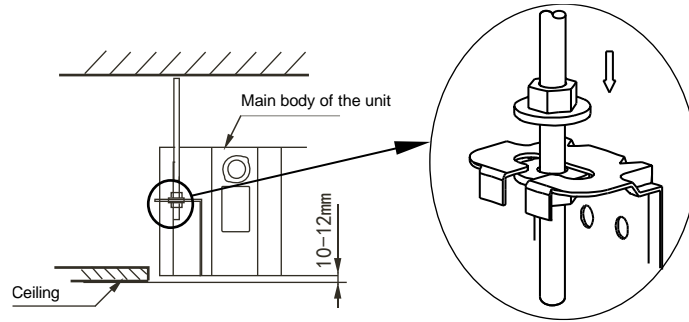
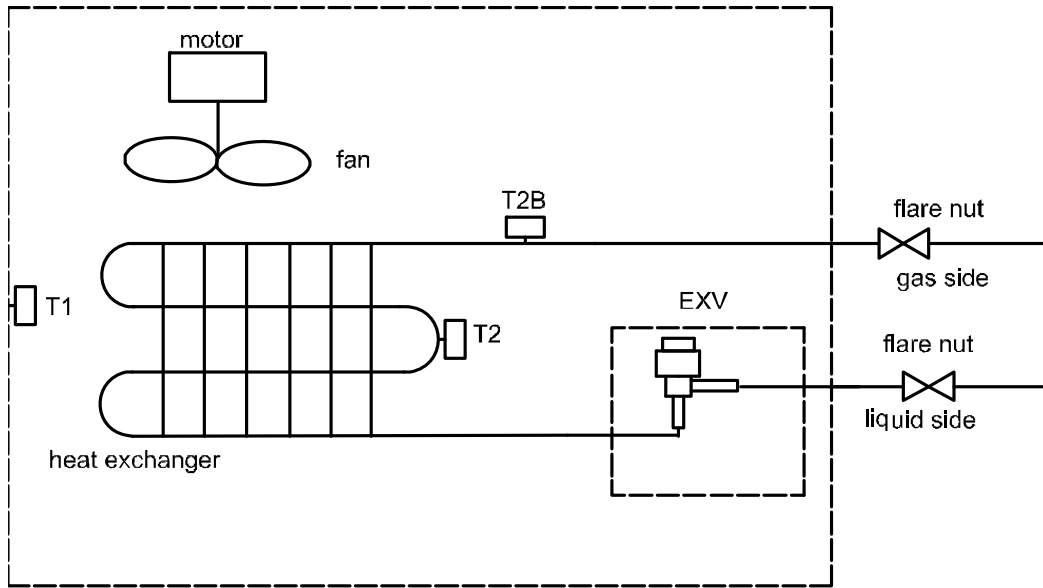

Legend	
T1	Indoor ambient temperature sensor
T2	Indoor heat exchanger mid-point temperature sensor
T2B	Indoor heat exchanger outlet temperature sensor

# The 2<sup>nd</sup> Generation DC Series VRF Indoor Units



## 5 Wiring Diagram

Figure 5.1: MI2-28Q4DHN1, MI2-36Q4DHN1, MI2-45Q4DHN1, MI2-56Q4DHN1, MI2-71Q4DHN1, MI2-80Q4DHN1

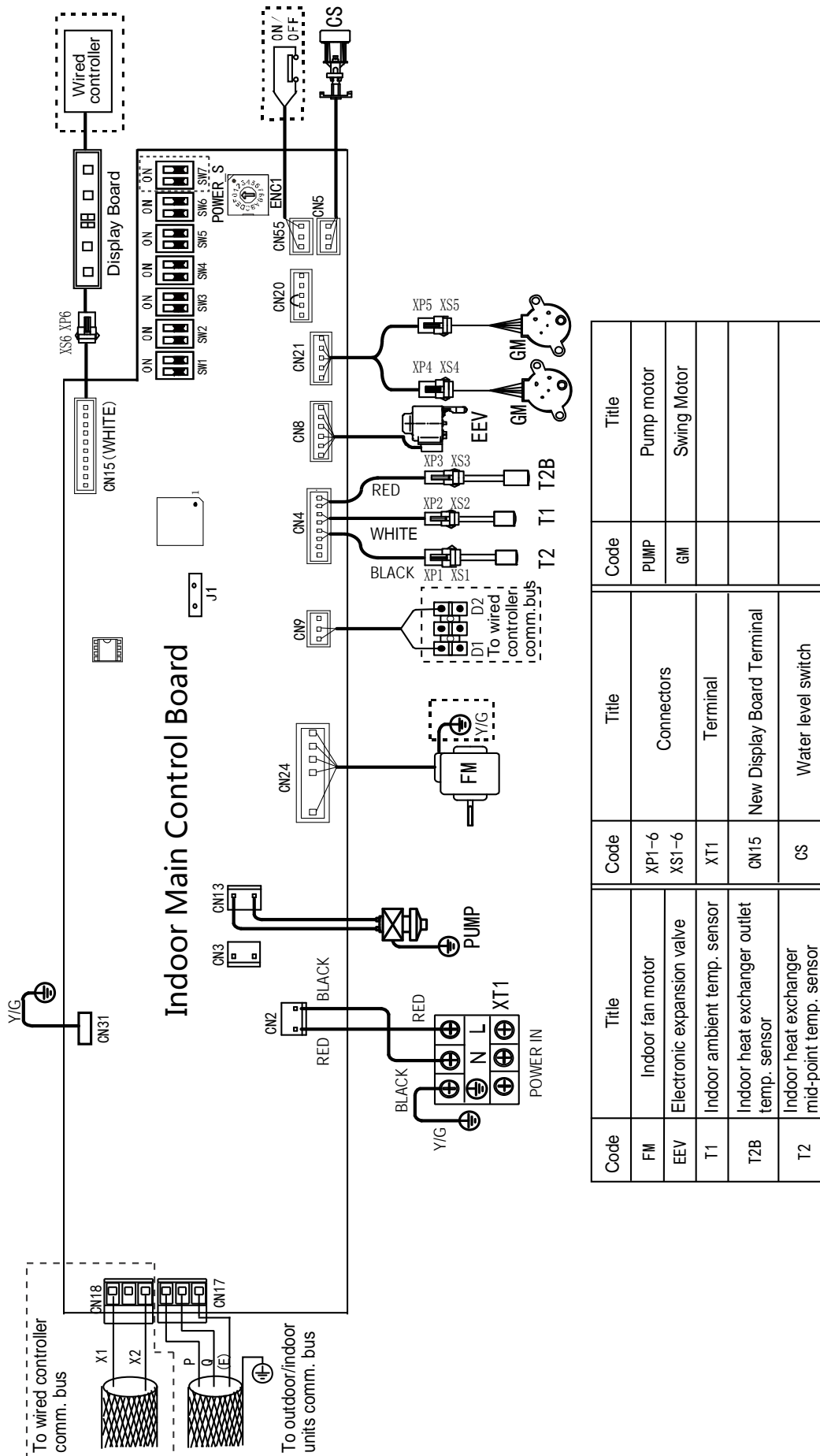

Code	Title	Code	Title	Code	Title
FM	Indoor fan motor	XP1-6	Connectors		
EEV	Electronic expansion valve	XS1-6			PUMP
T1	Indoor ambient temp. sensor	XT1	Terminal	GM	Swing Motor
T2B	Indoor heat exchanger outlet temp. sensor	CN15	New Display Board Terminal		
T2	Indoor heat exchanger mid-point temp. sensor	CS	Water level switch		

Figure 5.2: MI2-90Q4DHN1, MI2-100Q4DHN1, MI2-112Q4DHN1, MI2-140Q4DHN1

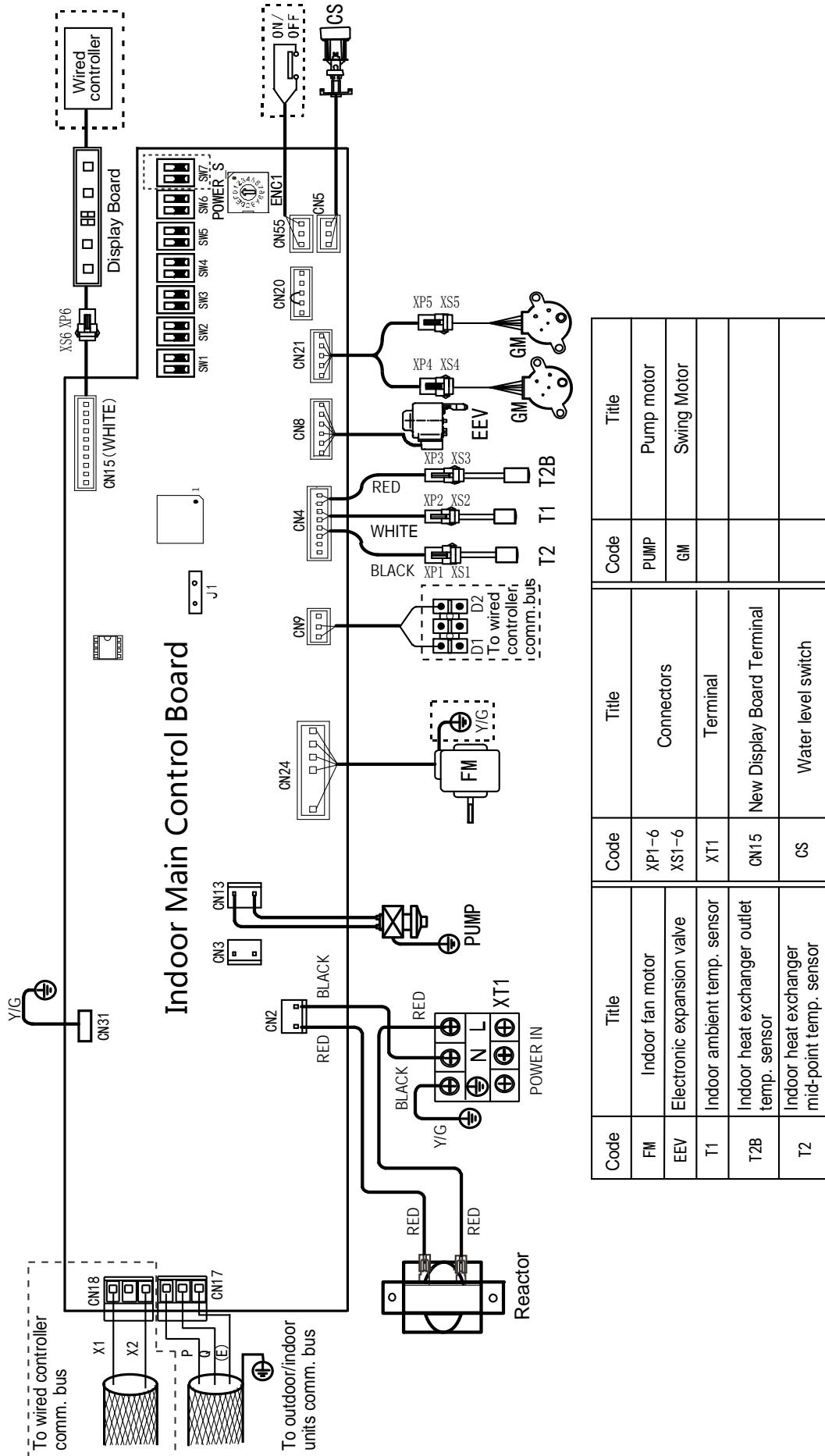

Code	Title	Code	Title	Code	Title
FM	Indoor fan motor	XP1-6	Connectors	PUMP	Pump motor
EEV	Electronic expansion valve	XS1-6		GM	Swing Motor
T1	Indoor ambient temp. sensor	XT1	Terminal		
T2B	Indoor heat exchanger outlet temp. sensor	CN15	New Display Board Terminal		
T2	Indoor heat exchanger mid-point temp. sensor	CS	Water level switch		

## Notes for installers and service engineers

### Caution

- All installation, servicing and maintenance must be carried out by competent and suitably qualified, certified and accredited professionals and in accordance with all applicable legislation.
- Units should be grounded in accordance with all applicable legislation. Metal and other conductive components should be insulated in accordance with all applicable legislation.
- Power supply wiring should be securely fastened at the power supply terminals – loose power supply wiring would represent a fire risk.
- After installation, servicing or maintenance, the electric control box cover should be closed. Failing to close the electric control box cover risks fire or electric shock.
- Switch ENC1 (indoor unit capacity setting) is factory-set and its setting should normally not be changed. The only circumstances in which a switch ENC1 might need to be set in the field is when replacing a main PCB. When replacing a main PCB, ensure that the capacity setting on switch ENC1 on the new PCB is consistent with the unit capacity given on the unit's nameplate.

## 6 Capacity Tables

### 6.1 Cooling Capacity Table

Table 6.1: Four-way Cassette cooling capacity

Model	Indoor air temperature (°C WB/DB)													
	14/20		16/23		18/26		19/27		20/28		22/30		24/32	
	TC	SC	TC	SC	TC	SC	TC	SC	TC	SC	TC	SC	TC	SC
MI2-28Q4DHN1	2.5	2.5	2.7	2.6	2.8	2.5	2.8	2.4	2.9	2.4	2.9	2.2	3.0	2.1
MI2-36Q4DHN1	3.2	3.2	3.4	3.2	3.6	3.2	3.6	3.0	3.7	3.0	3.8	2.8	3.9	2.7
MI2-45Q4DHN1	4.0	3.8	4.3	3.9	4.5	3.9	4.5	3.7	4.6	3.6	4.7	3.4	4.8	3.3
MI2-56Q4DHN1	5.0	4.8	5.3	4.8	5.6	4.8	5.6	4.6	5.7	4.5	5.8	4.2	6.0	4.1
MI2-71Q4DHN1	6.3	6.0	6.7	6.0	7.0	6.0	7.1	5.8	7.2	5.7	7.4	5.4	7.6	5.2
MI2-80Q4DHN1	7.1	6.9	7.6	6.9	7.9	6.8	8.0	6.6	8.1	6.4	8.3	6.1	8.5	5.8
MI2-90Q4DHN1	8.0	7.6	8.5	7.6	8.9	7.6	9.0	7.3	9.1	7.1	9.4	6.8	9.6	6.5
MI2-100Q4DHN1	8.9	8.6	9.5	8.6	9.9	8.5	10.0	8.2	10.1	7.9	10.4	7.6	10.6	7.2
MI2-112Q4DHN1	9.9	9.5	10.6	9.6	11.1	9.5	11.2	9.2	11.3	8.9	11.6	8.4	11.9	8.1
MI2-140Q4DHN1	12.4	11.7	13.2	11.7	13.8	11.6	14.0	11.3	14.2	11.0	14.5	10.5	14.9	10.1

Abbreviations:

TC: Total capacity (kW)

SC: Sensible capacity (kW)

Notes:

1. Shaded cells indicate rating condition

### 6.2 Heating Capacity Table

Table 6.2: Four-way Cassette heating capacity

Model	Indoor air temperature (°C DB)					
	16	18	20	21	22	24
	TC	TC	TC	TC	TC	TC
MI2-28Q4DHN1	3.4	3.4	3.2	3.1	3.0	2.8
MI2-36Q4DHN1	4.2	4.2	4.0	3.8	3.8	3.5
MI2-45Q4DHN1	5.3	5.3	5.0	4.8	4.7	4.4
MI2-56Q4DHN1	6.7	6.6	6.3	6.1	5.9	5.5
MI2-71Q4DHN1	8.5	8.4	8.0	7.8	7.5	7.0
MI2-80Q4DHN1	9.5	9.5	9.0	8.7	8.5	7.8
MI2-90Q4DHN1	10.6	10.5	10.0	9.7	9.4	8.8
MI2-100Q4DHN1	11.8	11.7	11.1	10.8	10.4	9.7
MI2-112Q4DHN1	13.3	13.1	12.5	12.1	11.8	10.9
MI2-140Q4DHN1	17.0	16.8	16.0	15.5	15.0	13.9

Abbreviations:

TC: Total capacity (kW)

Notes:

1. Shaded cells indicate rating condition

## 7 Electrical Characteristics

Table 7.1: Four-way Cassette electrical characteristics

Model name	Power supply						Indoor fan motors	
	Hz	Volts	Min. volts	Max. volts	MCA	MFA	Rated motor output (kW)	FLA
MI2-28Q4DHN1	50/60	220-240	198	264	0.41	15	0.08	0.33
MI2-36Q4DHN1	50/60	220-240	198	264	0.41	15	0.08	0.33
MI2-45Q4DHN1	50/60	220-240	198	264	0.56	15	0.08	0.45
MI2-56Q4DHN1	50/60	220-240	198	264	0.56	15	0.08	0.45
MI2-71Q4DHN1	50/60	220-240	198	264	0.56	15	0.08	0.45
MI2-80Q4DHN1	50/60	220-240	198	264	0.76	15	0.08	0.61
MI2-90Q4DHN1	50/60	220-240	198	264	0.88	15	0.17	0.70
MI2-100Q4DHN1	50/60	220-240	198	264	1.00	15	0.17	0.80
MI2-112Q4DHN1	50/60	220-240	198	264	1.00	15	0.17	0.80
MI2-140Q4DHN1	50/60	220-240	198	264	1.20	15	0.17	0.96

Abbreviations:

MCA: Minimum Circuit Amps

MFA: Maximum Fuse Amps

FLA: Full Load Amps

## 8 Sound Levels

### 8.1 Overall

Table 8.1: Four-way Cassette sound pressure levels<sup>1</sup>

Model name	Sound pressure levels dB(A)						
	SSH	SH	H	M	L	SL	SSL
MI2-28Q4DHN1	32	31	30	28	28	26	23
MI2-36Q4DHN1	32	31	30	28	28	26	23
MI2-45Q4DHN1	35	34	31	31	30	28	26
MI2-56Q4DHN1	35	34	31	31	30	28	26
MI2-71Q4DHN1	35	35	34	31	30	28	27
MI2-80Q4DHN1	36	35	34	31	31	29	28
MI2-90Q4DHN1	37	35	34	31	31	30	28
MI2-100Q4DHN1	43	42	40	38	37	35	34
MI2-112Q4DHN1	43	42	40	38	37	35	34
MI2-140Q4DHN1	45	44	42	41	40	39	37

Notes:

1. Sound pressure levels are measured 1.4m below the unit in a semi-anechoic chamber. During in-situ operation, sound pressure levels may be higher as a result of ambient noise.

Figure 8.1: Four-way Cassette sound pressure level measurement

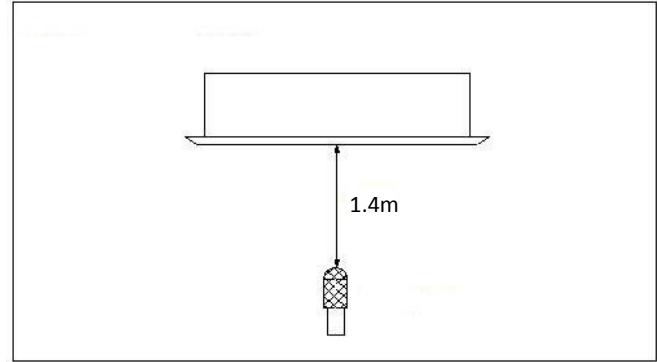

### 8.2 Octave Band Levels

Figure 8.2: MI2-28(36)Q4DHN1 octave band levels

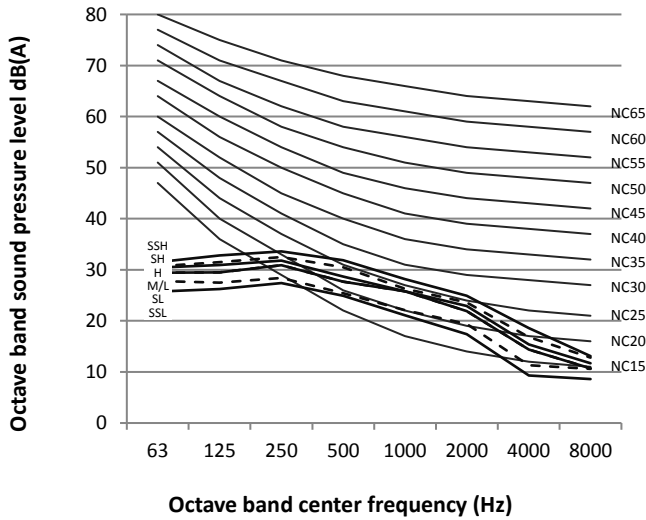
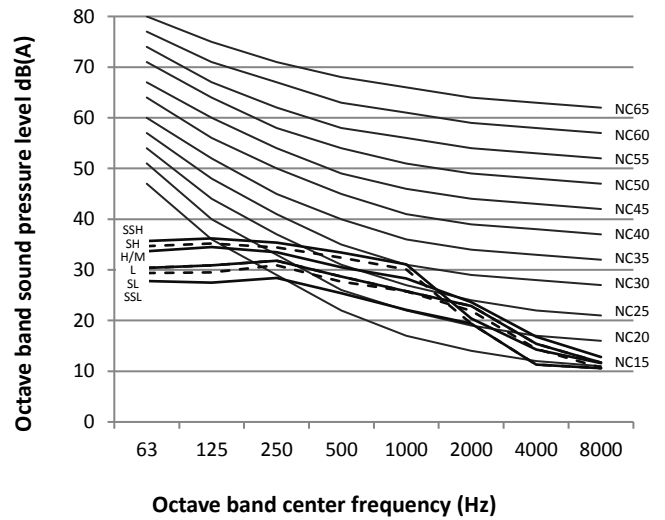

Figure 8.3: MI2-45(56)Q4DHN1 octave band levels





# The 2<sup>nd</sup> Generation DC Series VRF Indoor Units



Figure 8.4: MI2-71Q4DHN1 octave band levels

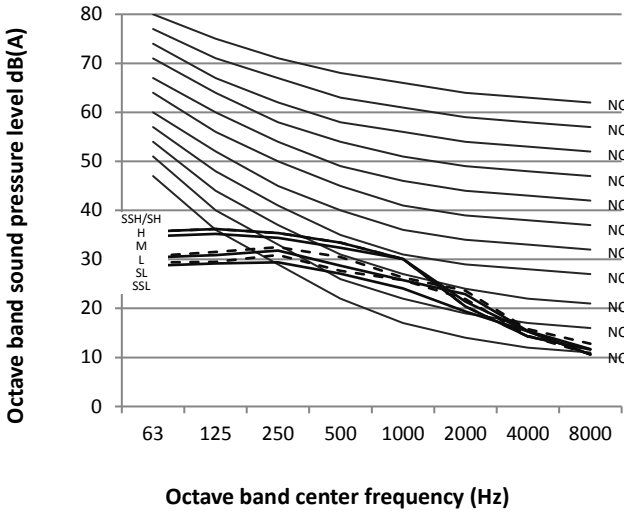

Figure 8.5: MI2-80Q4DHN1 octave band levels

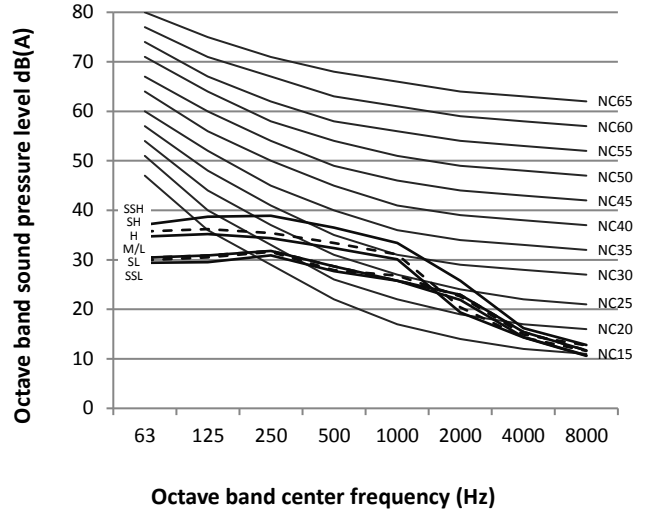

Figure 8.6: MI2-90Q4DHN1 octave band levels

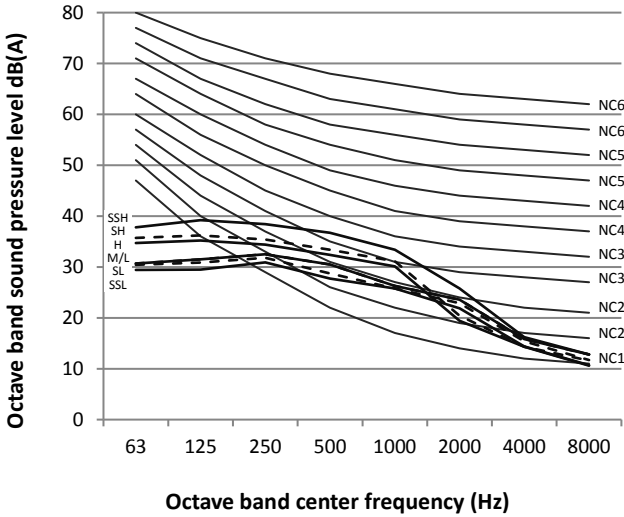

Figure 8.7: MI2-100(112)Q4DHN1 octave band levels

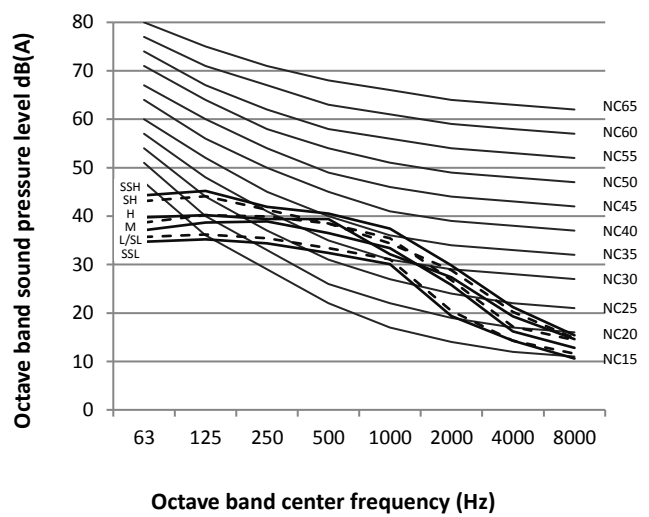
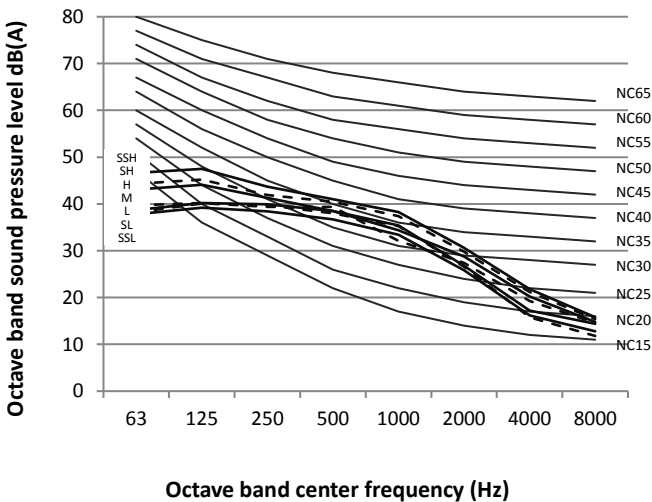

Figure 8.8: MI2-140Q4DHN1 octave band levels



## 9 Temperature and Airflow Distributions

### 9.1 Simulate condition

Table 9.1: Four-way Cassette simulate condition

Model name	Room size (m)	Ceiling height (m)	Flow angle (Cooling/Heating)	Placing
MI2-28Q4DHN1	6*6	2.7	15° /50°	Center
MI2-36Q4DHN1	6*6	2.7	15° /50°	Center
MI2-45Q4DHN1	6*6	2.7	15° /50°	Center
MI2-56Q4DHN1	8*8	2.7	15° /50°	Center
MI2-71Q4DHN1	8*8	2.7	15° /50°	Center
MI2-80Q4DHN1	8*8	2.7	15° /50°	Center
MI2-90Q4DHN1	10*10	2.7	15° /50°	Center
MI2-100Q4DHN1	10*10	2.7	15° /50°	Center
MI2-112Q4DHN1	10*10	2.7	15° /50°	Center
MI2-140Q4DHN1	10*10	2.7	15° /50°	Center

Note:

1. These figures and videos are based on software simulation. They show typical temperature and airflow distributions in the conditions above. In the actual installation, they may differ from these figures and videos under the influence of air temperature conditions, ceiling height, cooling/heating load, obstacles, etc.

### 9.2 Airflow distributions (unit: m/s)

Figure 9.1: MI2-28Q4DHN1 cooling at 120S

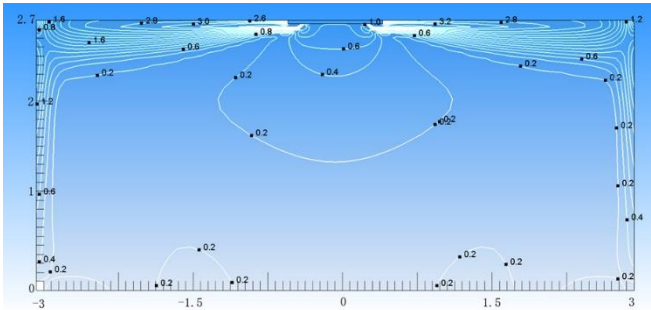

Figure 9.2: MI2-28Q4DHN1 heating at 120S

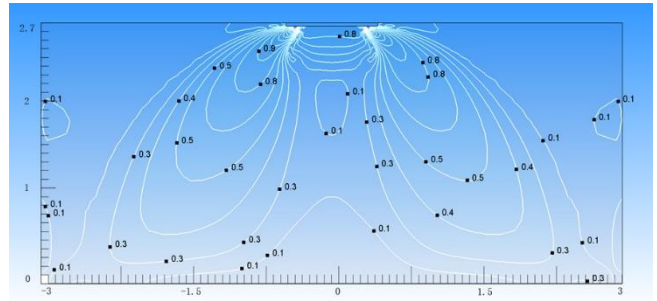

Figure 9.3: MI2-36Q4DHN1 cooling at 120S

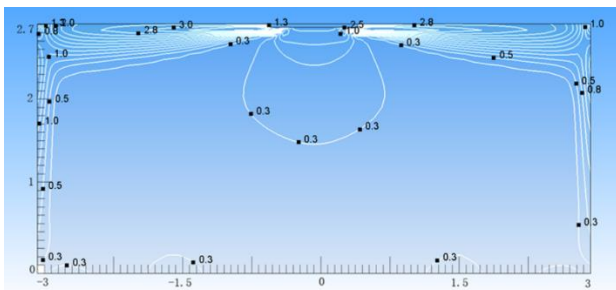

Figure 9.4: MI2-36Q4DHN1 heating at 120S

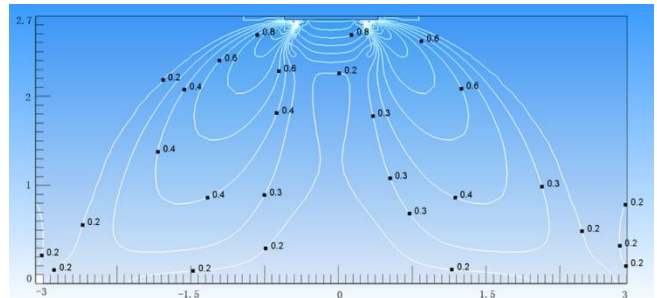

Figure 9.5: MI2-45Q4DHN1 cooling at 120S

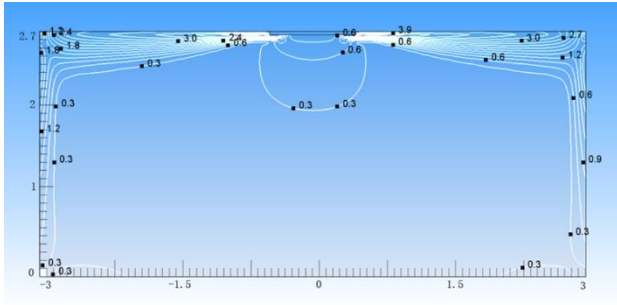

Figure 9.6: MI2-45Q4DHN1 heating at 120S

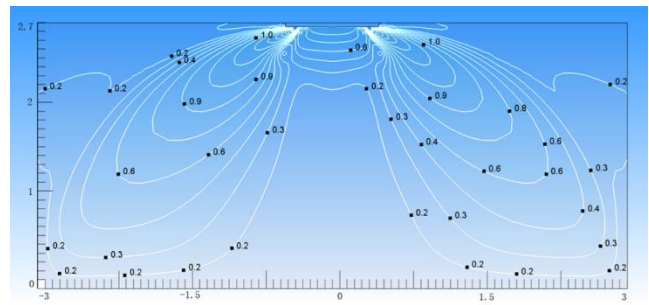

Figure 9.7: MI2-56Q4DHN1 cooling at 120S

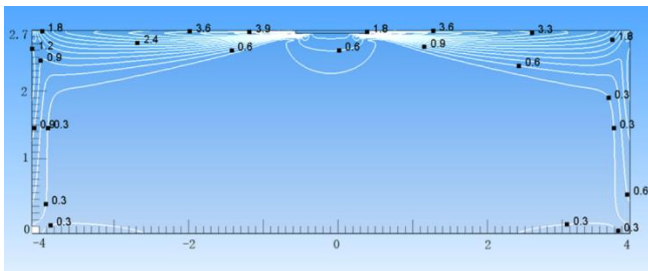

Figure 9.8: MI2-56Q4DHN1 heating at 120S

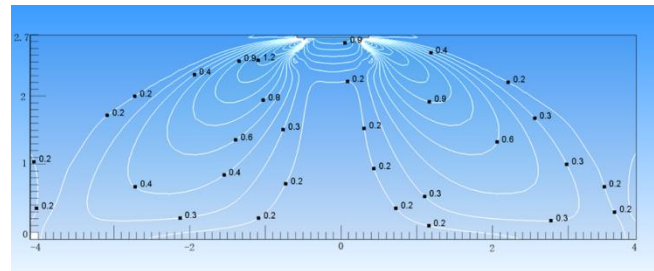

Figure 9.9: MI2-71Q4DHN1 cooling at 120S

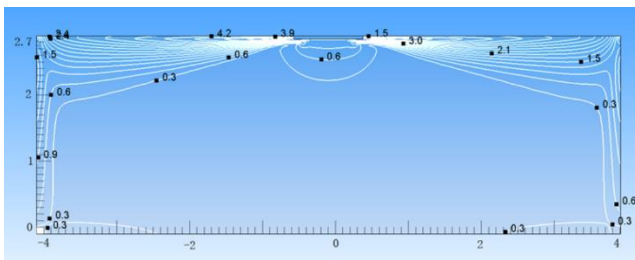

Figure 9.10: MI2-71Q4DHN1 heating at 120S

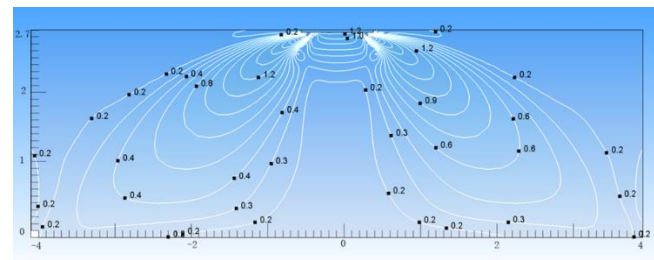

Figure 9.11: MI2-80Q4DHN1 cooling at 120S

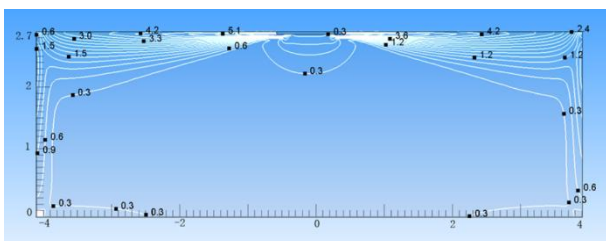

Figure 9.12: MI2-80Q4DHN1 heating at 120S

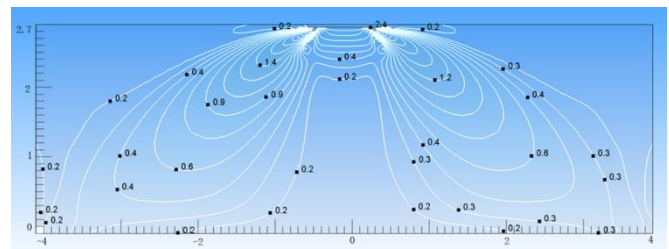

Figure 9.13: MI2-90Q4DHN1 cooling at 120S

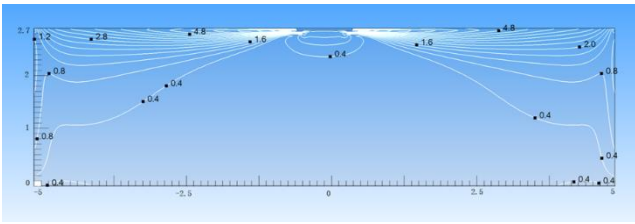

Figure 9.14: MI2-90Q4DHN1 heating at 120S

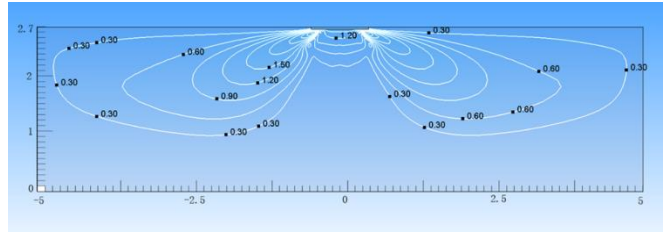

Figure 9.15: MI2-100Q4DHN1 cooling at 120S

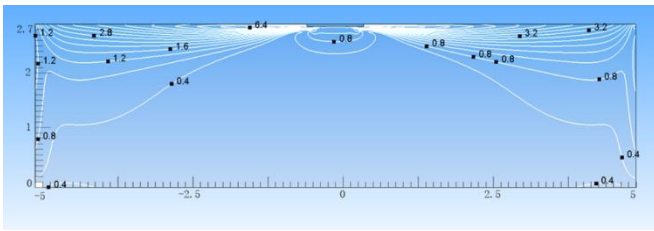

Figure 9.16: MI2-100Q4DHN1 heating at 120S

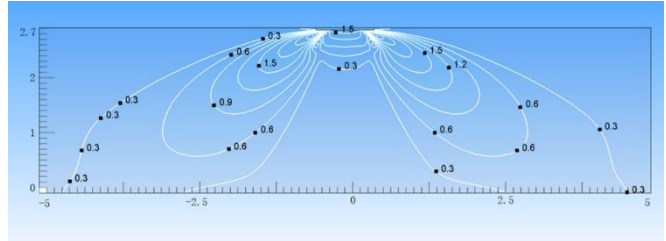

Figure 9.17: MI2-112Q4DHN1 cooling at 120S

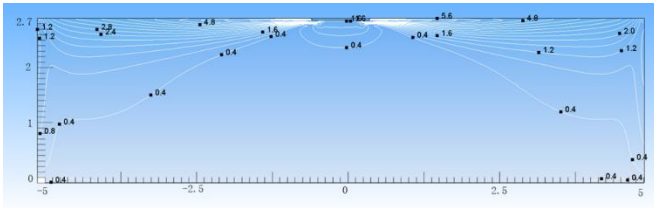

Figure 9.18: MI2-112Q4DHN1 heating at 120S

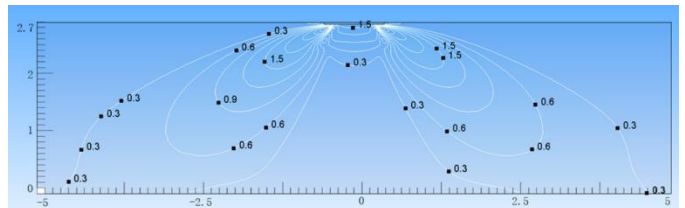

Figure 9.19: MI2-140Q4DHN1 cooling at 120S

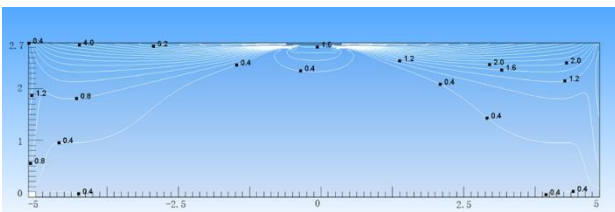
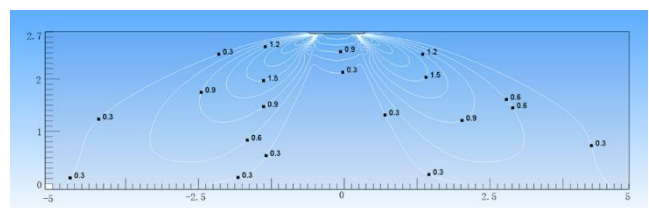

Figure 9.20: MI2-140Q4DHN1 heating at 120S



## 9.3 Temperature distributions (unit: °C)

Figure 9.21: MI2-28Q4DHN1 cooling at 120S

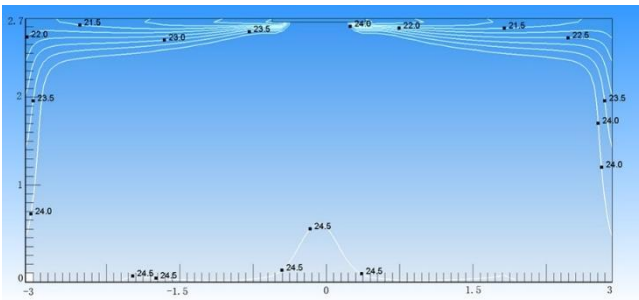

Figure 9.22: MI2-28Q4DHN1 heating at 120S

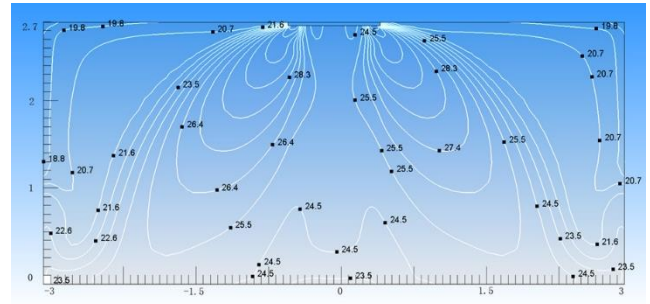

Figure 9.23: MI2-36Q4DHN1 cooling at 120S

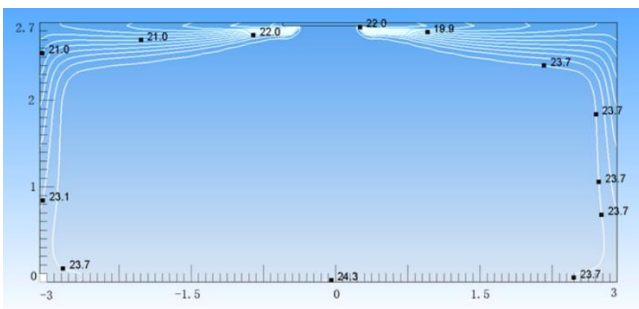

Figure 9.24: MI2-36Q4DHN1 heating at 120S

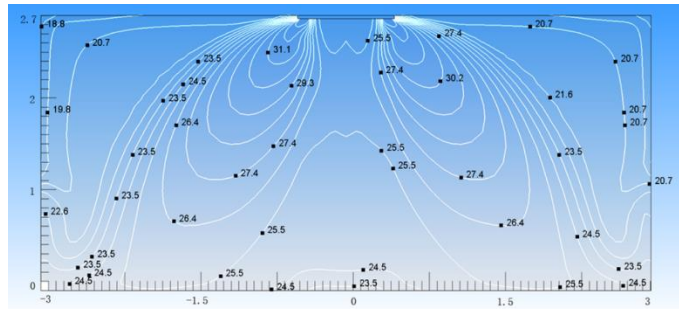

Figure 9.25: MI2-45Q4DHN1 cooling at 120S

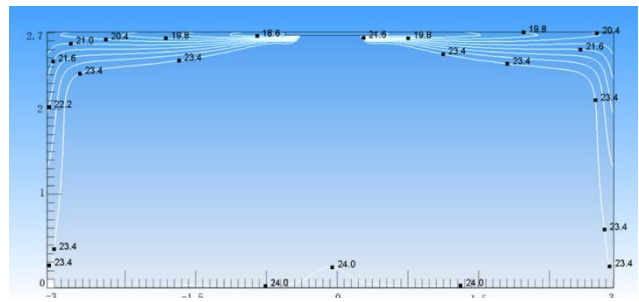

Figure 9.26: MI2-45Q4DHN1 heating at 120S

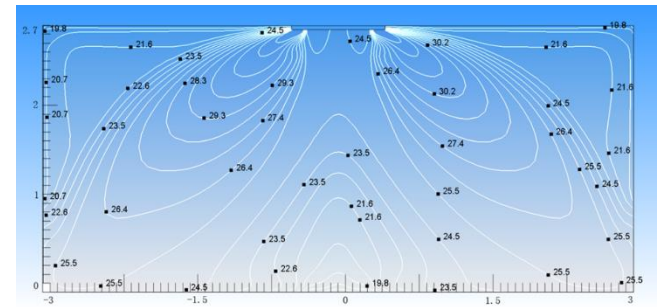

Figure 9.27: MI2-56Q4DHN1 cooling at 120S

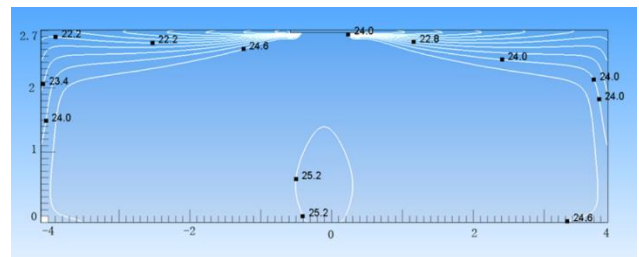

Figure 9.28: MI2-56Q4DHN1 heating at 120S

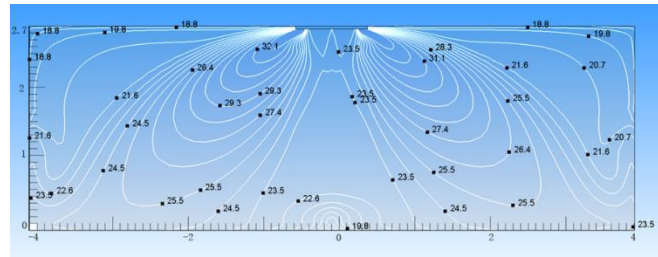

Figure 9.29: MI2-71Q4DHN1 cooling at 120S

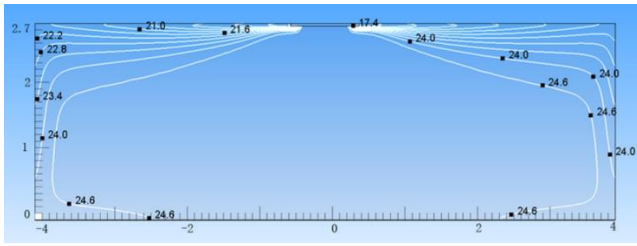

Figure 9.30: MI2-71Q4DHN1 heating at 120S

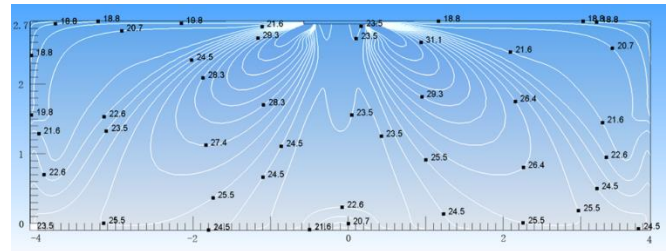

Figure 9.31: MI2-80Q4DHN1 cooling at 120S

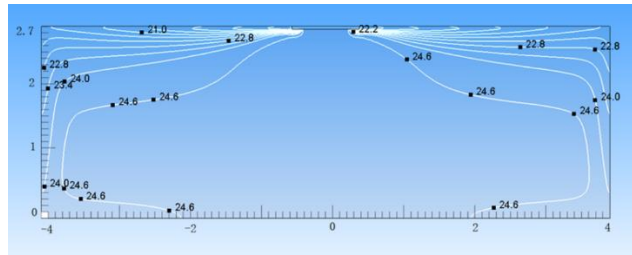

Figure 9.32: MI2-80Q4DHN1 heating at 120S

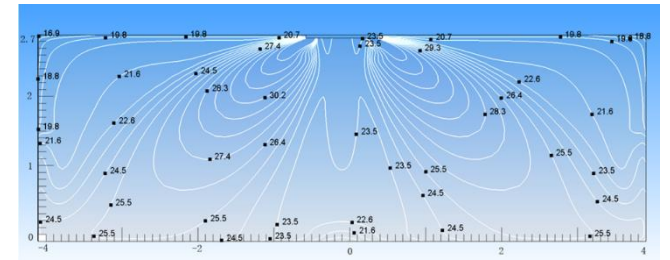

Figure 9.33: MI2-90Q4DHN1 cooling at 120S

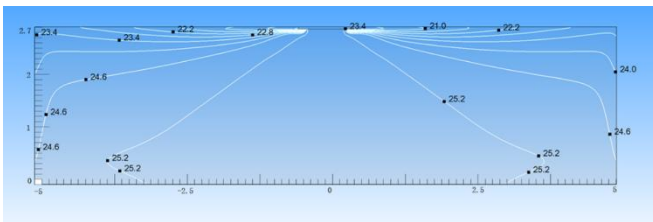

Figure 9.34: MI2-90Q4DHN1 heating at 120S

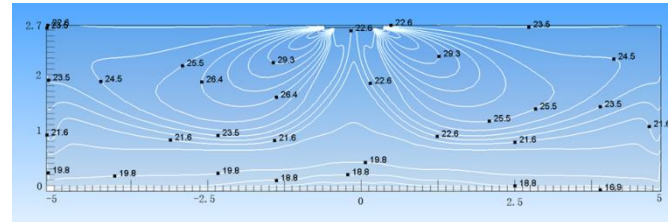

Figure 9.35: MI2-100Q4DHN1 cooling at 120S

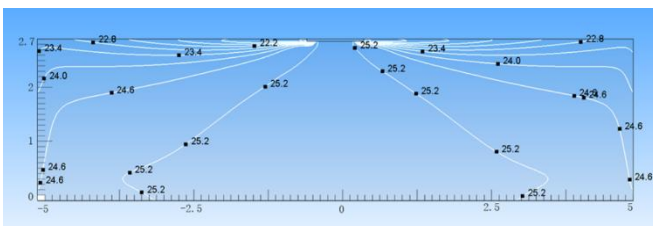

Figure 9.36: MI2-100Q4DHN1 heating at 120S

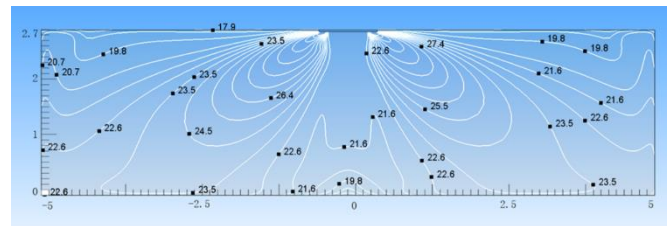

Figure 9.37: MI2-112Q4DHN1 cooling at 120S

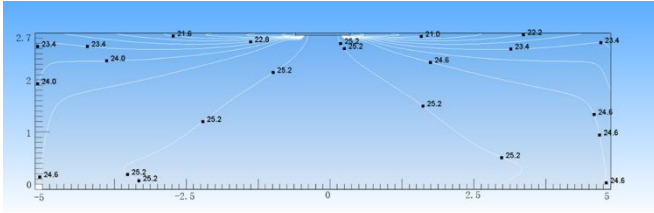

Figure 9.38: MI2-112Q4DHN1 heating at 120S

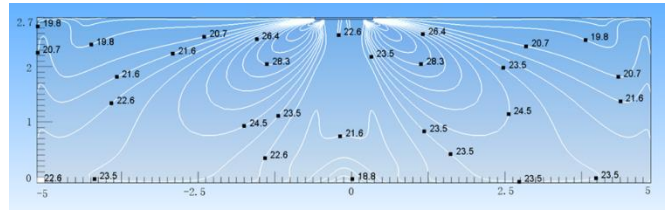

Figure 9.39: MI2-140Q4DHN1 cooling at 120S

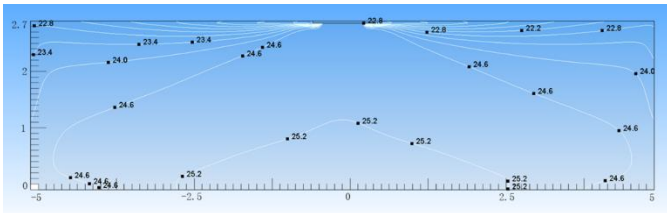
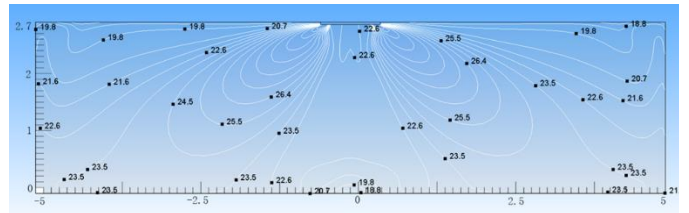

Figure 9.40: MI2-140Q4DHN1 heating at 120S







## Commercial Air Conditioner Division Midea Group

**Add.:** Midea Headquarters Building, 6 Midea Avenue, Shunde, Foshan, Guangdong, China

**Postal code:** 528311

[cac.midea.com](http://cac.midea.com) / [global.midea.com](http://global.midea.com)

Note: Product specifications change from time to time as product improvements and developments are released and may vary from those in this document.

