

Engineering Data

New Atom VRF IDU Arc Series Duct

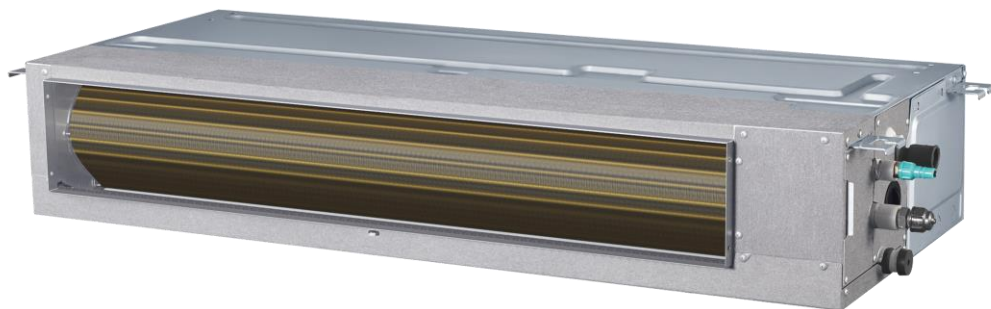

MVM15TA-VA1

MVM45TA-VA1

MVM22TA-VA1

MVM56TA-VA1

MVM28TA-VA1

MVM71TA-VA1

MVM36TA-VA1

New Atom VRF IDU Arc Series Duct

1 Specifications	3
2 Unit Dimensions.....	5
3 Unit Placement	7
4 Piping Diagram.....	8
5 Wiring Diagrams.....	9
6 Fan Performance	11
7 Capacity Tables.....	15
8 Electrical Characteristics.....	17
9 Sound Levels	18

1 Specifications

Table 1.1: MVM15 (22; 28) TA-VA1 specifications

Model name			MVM15TA-VA1	MVM22TA-VA1	MVM28TA-VA1
Power supply			1-phase, 220-240V, 50/60Hz		
Cooling ¹	Capacity	kBtu/h(kW)	5(1.5)	7(2.2)	9(2.8)
	Input power	W	24	25	31
Heating ²	Capacity	kBtu/h(kW)	6(1.8)	8(2.5)	10(3.2)
	Input power	W	24	25	31
Fan motor	Type		DC		
	Number		1		
Coil	Number of rows		2&3	2&3	2&3
	Fin spacing	mm	1.32	1.32	1.32
	Fin type		Hydrophilic aluminum		
	Tube OD and type	mm	Φ5 Inner groove		
	Number of circuits		4	4	4
Airflow rate ³	m ³ /h		340/330/320/ 310/300/295/290	370/345/335/ 320/310/300/295	460/430/410/ 380/350/320/300
External static pressure ⁴ (Std(Min~Max))	Pa		10(10-50)		
Sound pressure level ⁵	dB(A)		27/25.5/24/ 23/22/21/20	28/27/26/ 25/24/23/22	30/29/28/ 27/26/25/24
Unit	Net dimensions ⁶ (W×H×D)	mm	550×199×450		
	Packed dimensions (W×H×D)	mm	715×255×525		
	Net/Gross weight	kg	11.5/14		
Refrigerant type			R410A		
Pipe connections	Liquid/Gas pipe	mm	Φ6.35/Φ12.7		
	Drain pipe	mm	OD Φ25		

Notes:

- Indoor temperature 27°C DB, 19°C WB; outdoor temperature 35°C DB; equivalent refrigerant piping length 7.5m with zero level difference.
- Indoor temperature 20°C DB; outdoor temperature 7°C DB, 6°C WB; equivalent refrigerant piping length 7.5m with zero level difference.
- Fan motor speed and air flow rate are from the highest speed to the lowest speed, total 7 rates for each model.
- Stable operation external static pressure range. (Note: setting external static pressure outside the unit's optimal static pressure range may lead to higher noise levels and lower airflow rate. For the optimal external static pressure range refer to the unit's installation manual.)
- Sound pressure level is from highest level to lowest level, total 7 levels for each model. Sound pressure level is measured 1.4m below the unit in a semi-anechoic chamber.
- Unit body dimensions given are the largest external dimensions of the unit, including hanger attachments.

New Atom VRF IDU Arc Series Duct



Table 1.2: MVM36(45; 56; 71) TA-VA1 specifications

Model name			MVM36TA-VA1	MVM45TA-VA1	MVM56TA-VA1	MVM71TA-VA1
Power supply			1-phase, 220-240V, 50/60Hz			
Cooling ¹	Capacity	kBtu/h(kW)	12(3.6)	15(4.5)	19(5.6)	24(7.1)
	Input power	W	34	46	61	68
Heating ²	Capacity	kBtu/h(kW)	13(4)	17(5)	21(6.3)	27(8)
	Input power	W	34	46	61	68
Fan motor	Type		DC			
	Number		1			
Coil	Number of rows		2&3	2&3	2&3	2&3
	Fin spacing	1.32	1.32	1.32	1.32	1.32
	Fin type		Hydrophilic aluminum			
	Tube OD and type	mm	Φ5 Inner groove			
	Number of circuits		4	6	6	8
Airflow rate ³	m ³ /h		605/550/500/ 450/410/360/320	800/720/690/ 625/560/515/435	900/780/745/ 655/580/560/470	900/780/745/ 655/580/560/470
External static pressure ⁴ (Std(Min~Max))	Pa		10(10-50)			
Sound pressure level ⁵	dB(A)		30/29/28/ 27/26/25.5/25	34/33/32/ 30/29/28/26	36/34/33/ 32/31/30/28	37/35/34/ 32.5/31/30/29
Unit	Net dimensions ⁶ (W×H×D)	mm	700×199×450	900×199×450	900×199×450	1100×199×450
	Packed dimensions (W×H×D)	mm	865×255×525	1065×255×525	1065×255×525	1300×255×525
	Net/Gross weight	kg	13/15.5	16.5/19.5	16.5/19.5	20/23.5
Refrigerant type			R410A			
Pipe connections	Liquid/Gas pipe	mm	Φ6.35/Φ12.7	Φ6.35/Φ12.7	Φ9.53/Φ15.9	Φ9.53/Φ15.9
	Drain pipe	mm	OD Φ25			

Notes:

- Indoor temperature 27°C DB, 19°C WB; outdoor temperature 35°C DB; equivalent refrigerant piping length 7.5m with zero level difference.
- Indoor temperature 20°C DB; outdoor temperature 7°C DB, 6°C WB; equivalent refrigerant piping length 7.5m with zero level difference.
- Fan motor speed and air flow rate are from the highest speed to the lowest speed, total 7 rates for each model.
- Stable operation external static pressure range. (Note: setting external static pressure outside the unit's optimal static pressure range may lead to higher noise levels and lower airflow rate. For the optimal external static pressure range refer to the unit's installation manual.)
- Sound pressure level is from highest level to lowest level, total 7 levels for each model. Sound pressure level is measured 1.4m below the unit in a semi-anechoic chamber.
- Unit body dimensions given are the largest external dimensions of the unit, including hanger attachments.

2 Unit Dimensions

Figure 2.1: External dimensions and size of air outlet opening

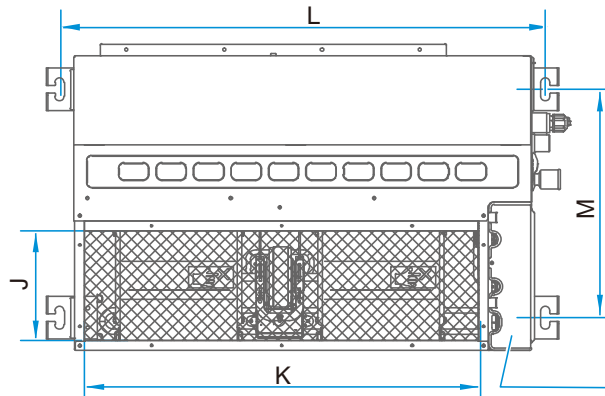
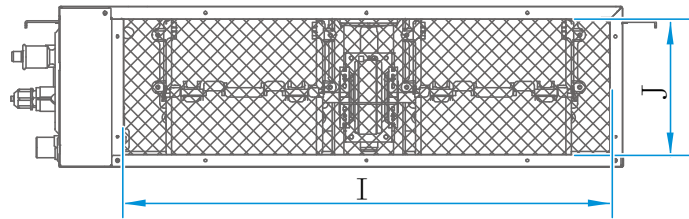
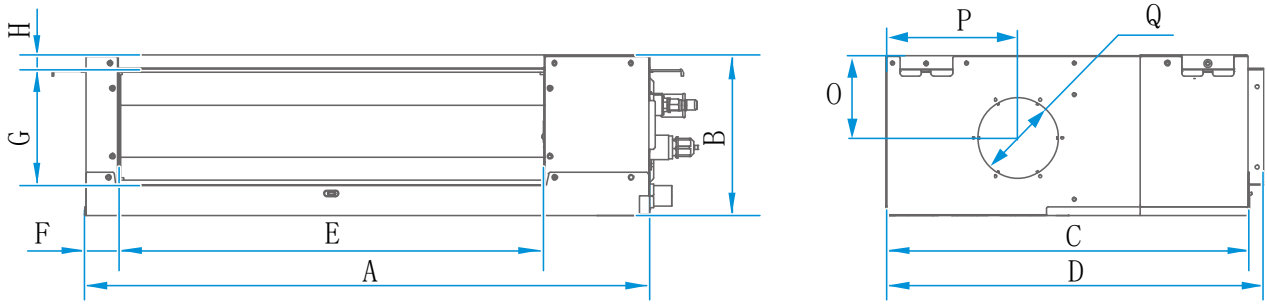

Electric control assembly

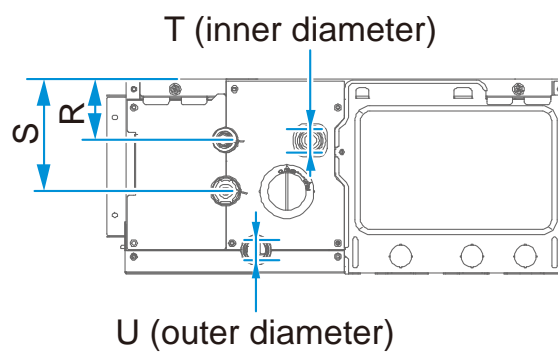

New Atom VRF IDU Arc Series Duct



Table 2.1: Arc series duct dimensions (unit: mm)

Model	Dimensions				Size of air outlet (Flange)			
	A	B	C	D	E	F	G	H
MVM15TA-VA1 MVM22TA-VA1 MVM28TA-VA1	550	199	450	470	380	41	145	17
MVM36TA-VA1	700	199	450	470	530	41	145	17
MVM45TA-VA1 MVM56TA-VA1	900	199	450	470	730	41	145	17
MVM71TA-VA1)	1100	199	450	470	930	41	145	17

Table 2.2: Arc series duct dimensions (unit: mm) (continued)

Model	Size of Return Air Inlet			Spacing between lugs		Size of Fresh Air Outlet		
	I	J	K	L	M	O	P	Q
MVM15TA-VA1 MVM22TA-VA1 MVM28TA-VA1	455	170	455	595	350	103	163	100
MVM36TA-VA1	605	170	605	745	350	103	163	100
MVM45TA-VA1 MVM56TA-VA1	805	170	805	945	350	103	163	100
MVM71TA-VA1)	1005	170	1005	1145	350	103	163	100

Figure 2.1: Arc series duct dimensions (unit: mm)

Model	Pipe Size		Water Pipe Size	
	R	S	T	U
MVM15TA-VA1 MVM22TA-VA1 MVM28TA-VA1	62	115	23	25
MVM36TA-VA1	62	115	23	25
MVM45TA-VA1 MVM56TA-VA1	62	115	23	25
MVM71TA-VA1)	62	115	23	25

3 Unit Placement

3.1 Placement Considerations

Unit placement should take account of the following considerations:

- Units should not be installed in the following locations:
 - Where exposure to direct radiation from a high-temperature heat source or to interference from a source of electromagnetic radiation may occur.
 - Where dust or dirt may affect heat exchangers.
 - Where exposure to oil or to corrosive or harmful gases, such as acidic or alkaline gases, may occur.
 - Where exposure to salinity may occur, such as seaside locations.
 - Where highly flammable materials are present.
 - Where exposure to oily air may occur, such as a kitchen.
 - Where exposure to very high humidity may occur, such as a laundry.
- Units should be installed in positions where:
 - The ceiling is horizontal and is able to bear the unit's weight.
 - There are no obstructions that could impede the airflow into and out of the unit.
 - The airflow out of the unit can reach throughout the room.
 - There is sufficient space for access during installation, servicing and maintenance.
 - The refrigerant piping and drain piping can be easily connected to the refrigerant piping and drain piping systems.
 - Short-circuit ventilation (where outlet air returns quickly to a unit's air inlet) will not occur.

3.2 Space Requirements

Figure 3.1: Arc series Duct space requirements (unit: mm)

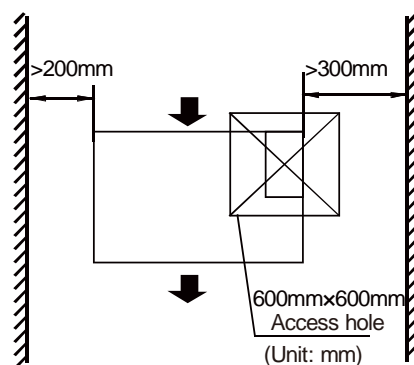

4 Piping Diagram

Figure 4.1: Arc series Duct piping diagram

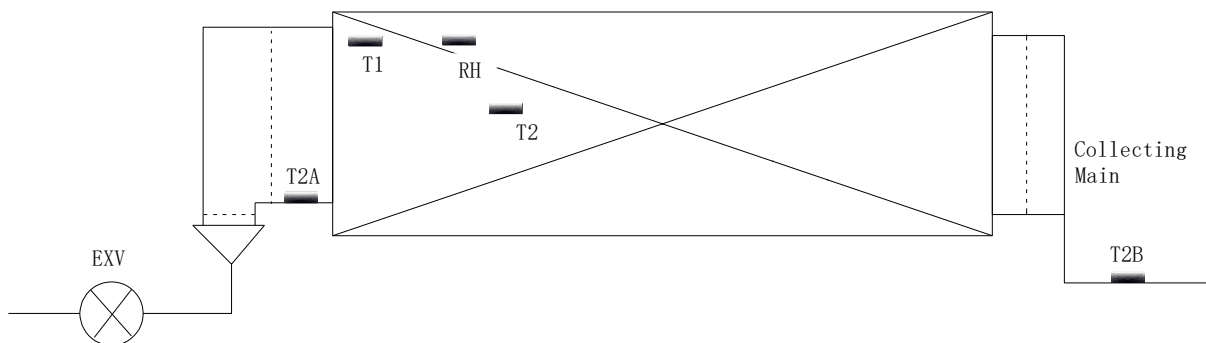

Legend	
T1	Indoor ambient temperature sensor
T2	Indoor heat exchanger mid-point temperature sensor
T2A	Indoor heat exchanger inlet temperature sensor
T2B	Indoor heat exchanger outlet temperature sensor
RH	Indoor relative humidity sensor

5 Wiring Diagrams

Figure 5.1: Arc series Duct wiring diagram

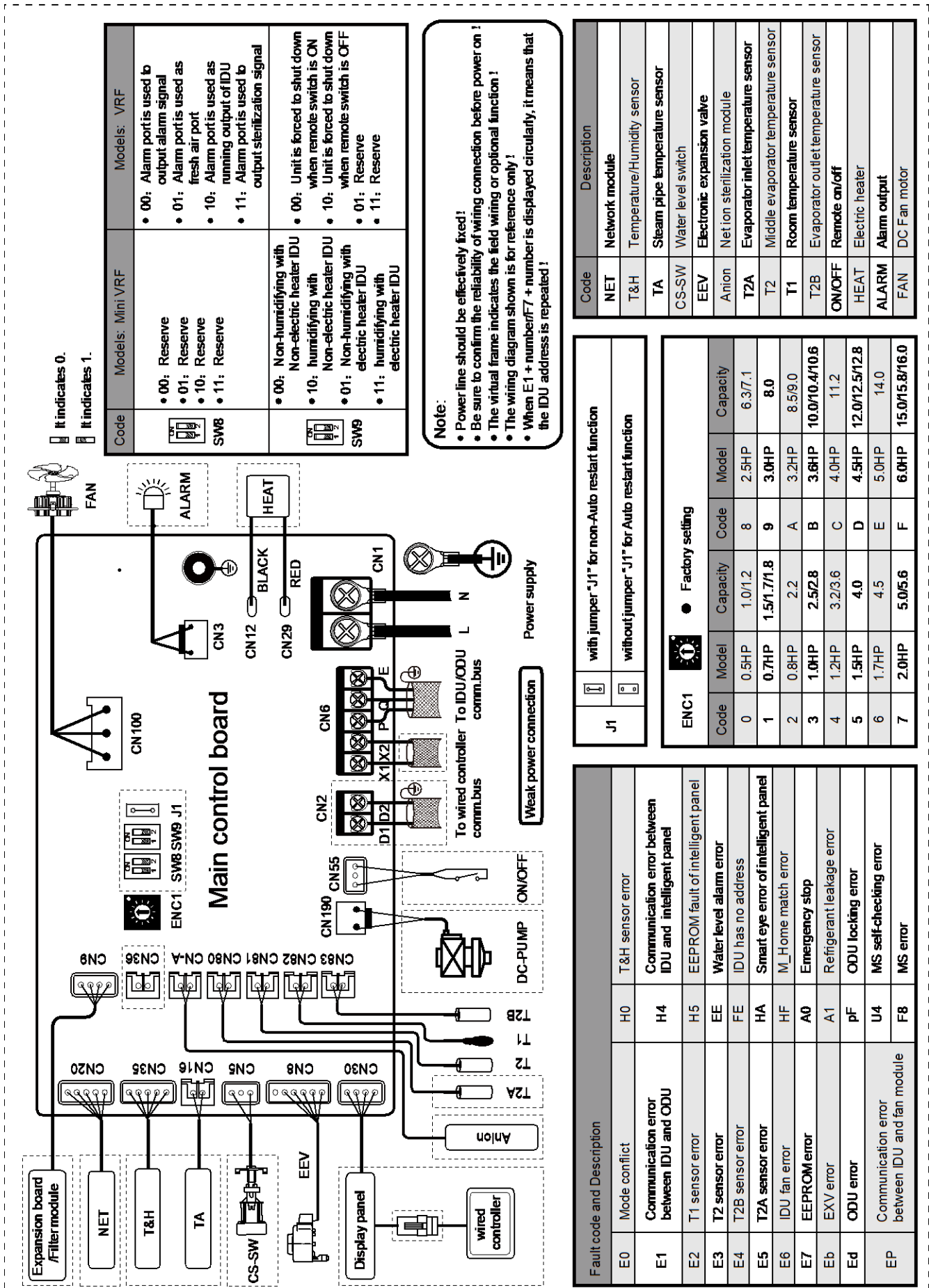

Notes for installers and service engineers

Caution

- All installation, servicing and maintenance must be carried out by competent and suitably qualified, certified and accredited professionals and in accordance with all applicable legislation.
- Units should be grounded in accordance with all applicable legislation. Metal and other conductive components should be insulated in accordance with all applicable legislation.
- Power supply wiring should be securely fastened at the power supply terminals – loose power supply wiring would represent a fire risk.
- After installation, servicing or maintenance, the electric control box cover should be closed. Failing to close the electric control box cover risks fire or electric shock.
- Switch ENC1 (indoor unit capacity setting) is factory-set and its setting should normally not be changed. The only circumstances in which a switch ENC1 might need to be set in the field is when replacing a main PCB. When replacing a main PCB, ensure that the capacity setting on switch ENC1 on the new PCB is consistent with the unit capacity given on the unit's nameplate.

6 Fan Performance

Figure 6.1: MVM15TA-VA1 (At) fan performance

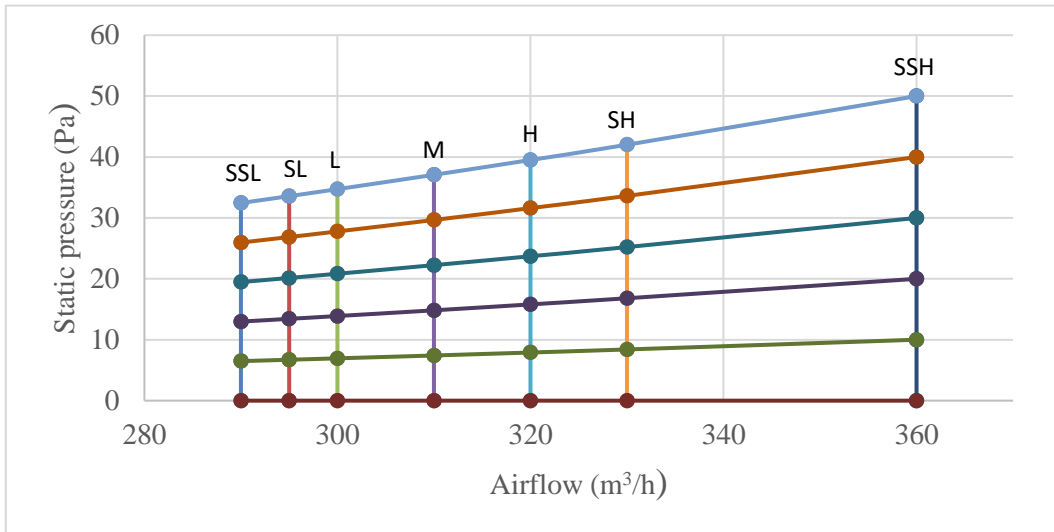
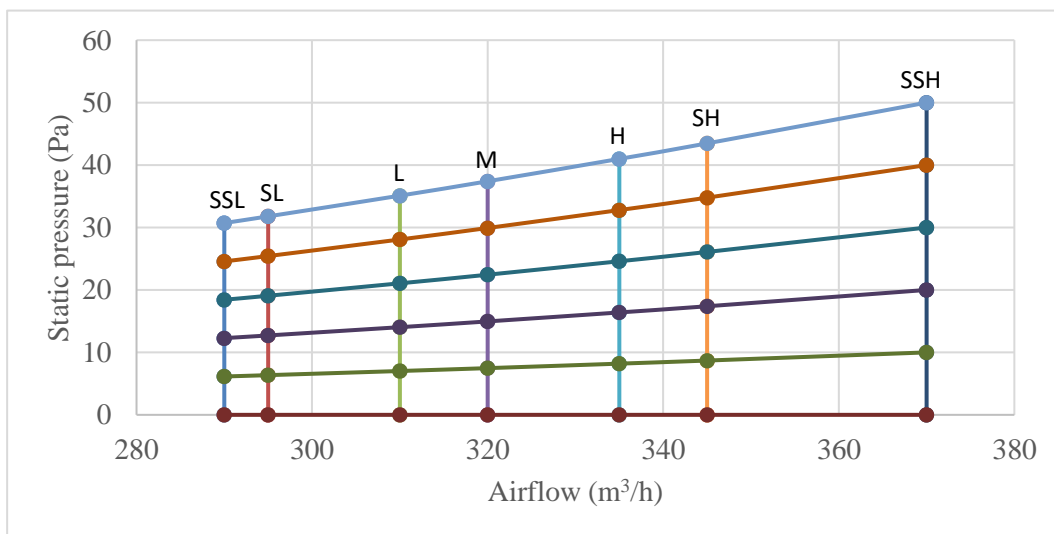

Figure 6.2: MVM22TA-VA1(At) fan performance



New Atom VRF IDU Arc Series Duct



Figure 6.3: MVM28TA-VA1(At) fan performance

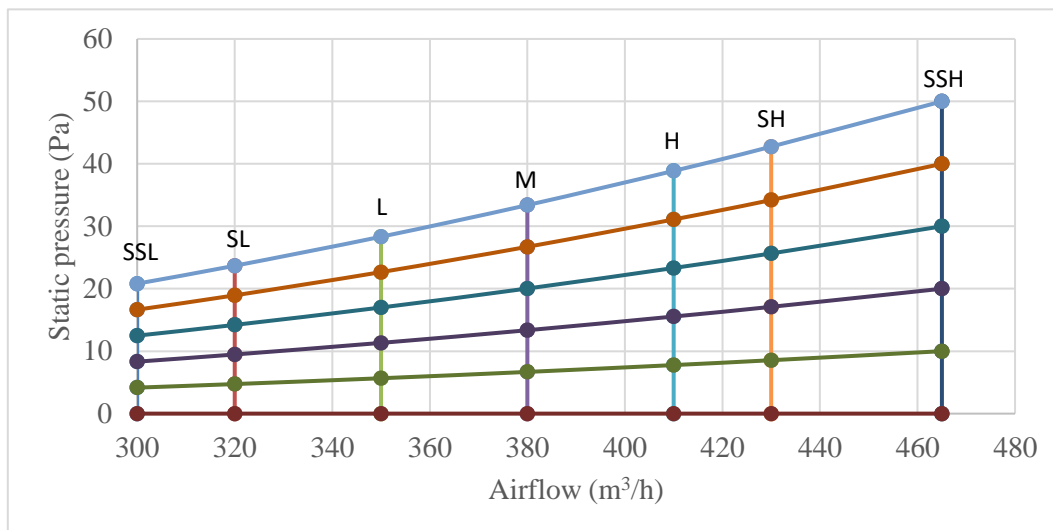

Figure 6.4: MVM36TA-VA1(At) fan performance

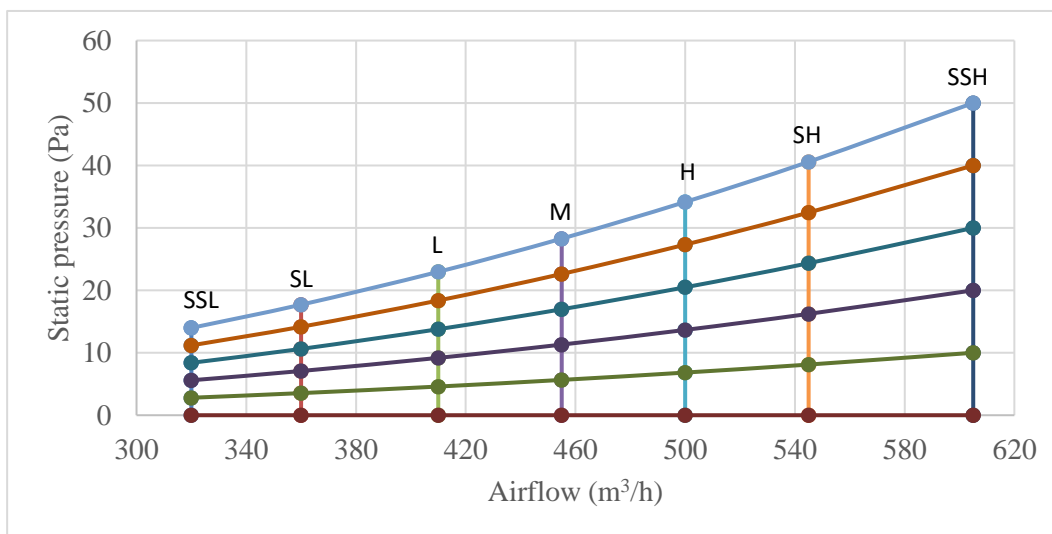

Figure 6.5: MVM45TA-VA1 (At) fan performance

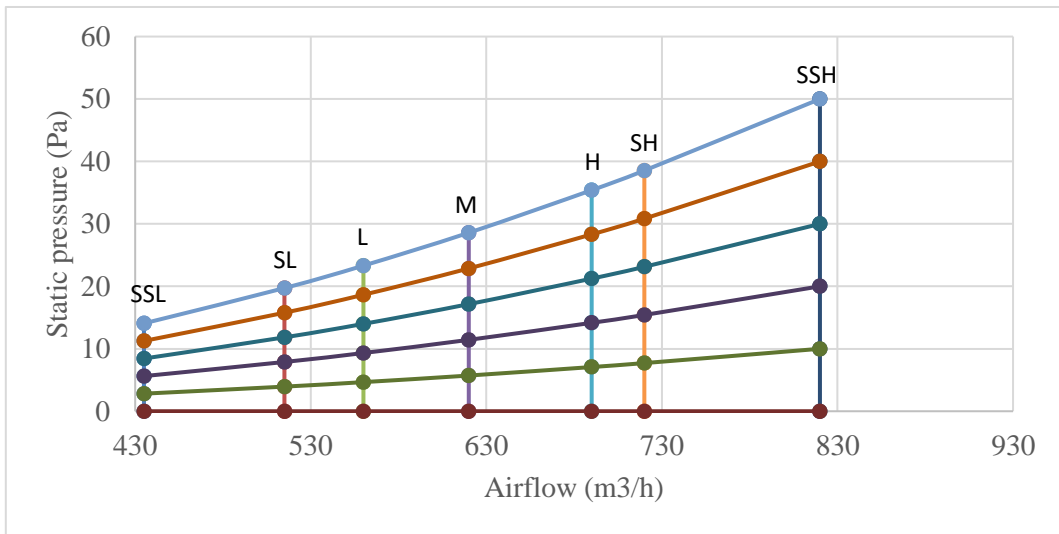
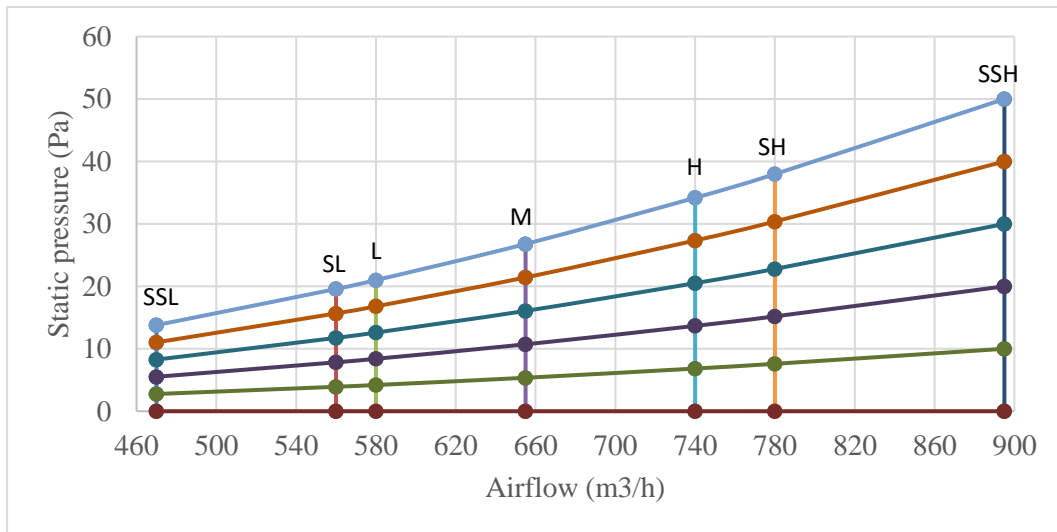

Figure 6.6: MVM56TA-VA1(At) fan performance



New Atom VRF IDU Arc Series Duct



Figure 6.7: MVM71TA-VA1(At) fan performance

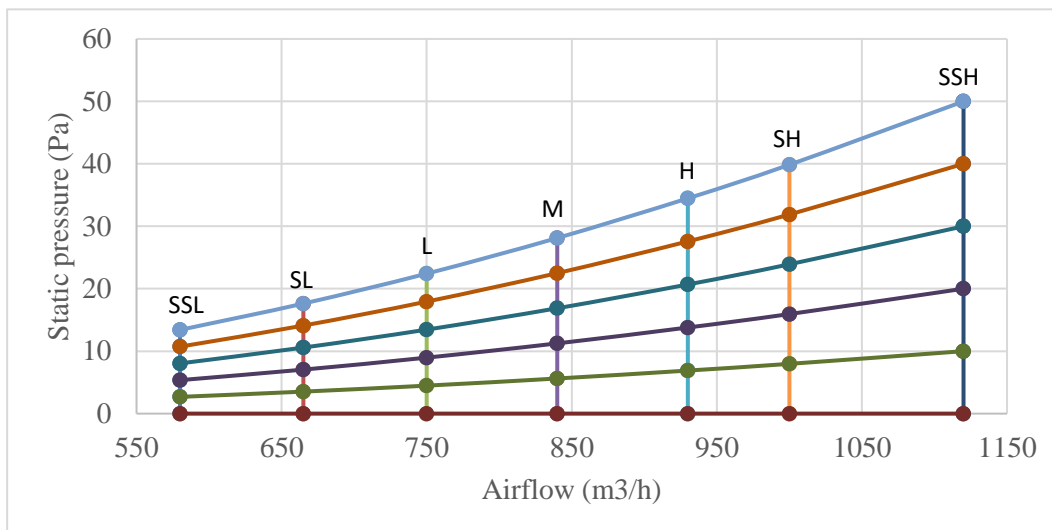

Table 6.1: ESP settings through the wired controller

Capacity	00	01	02	03	04	05	06	07
1.5-7.1kW	10Pa	20Pa	30Pa	40Pa	50Pa	50Pa	50Pa	50Pa

7 Capacity Tables

7.1 Cooling Capacity Table

Table 7.1: Arc series duct cooling capacity

Model	Indoor air temperature (°C WB/DB)													
	14/20		16/23		18/26		19/27		20/28		22/30		24/32	
	TC	SC	TC	SC	TC	SC	TC	SC	TC	SC	TC	SC	TC	SC
MVM15TA-VA1	0.8	0.7	1.1	0.9	1.4	1.0	1.5	1.1	1.6	1.1	2.0	1.2	2.3	1.3
MVM22TA-VA1	1.2	1.1	1.6	1.4	2.0	1.6	2.2	1.6	2.4	1.7	2.8	1.7	3.2	1.8
MVM28TA-VA1	1.5	1.3	2.0	1.6	2.5	1.8	2.8	1.9	3.1	2.0	3.7	2.2	4.4	2.3
MVM36TA-VA1	1.9	1.8	2.5	2.1	3.2	2.4	3.6	2.5	4.0	2.6	4.7	2.8	5.5	3.0
MVM45TA-VA1	2.5	2.2	3.3	2.7	4.1	3.1	4.5	3.2	4.9	3.3	5.8	3.5	6.7	3.6
MVM56TA-VA1	3.2	2.9	4.1	3.4	5.1	4.0	5.6	4.1	6.1	4.2	7.1	4.4	8.1	4.5
MVM71TA-VA1	3.6	3.2	5.0	4.1	6.4	4.8	7.1	5.0	7.4	5.2	8.4	5.4	9.2	5.6

Abbreviations:

TC: Total capacity (kW)

SC: Sensible capacity (kW)

Notes:

1. Shaded cells indicate rating condition

7.2 Heating Capacity Table

Table 7.2: Arc series duct heating capacity

Model	Indoor air temperature (°C DB)					
	16	18	20	21	22	24
	TC	TC	TC	TC	TC	TC
MVM15TA-VA1	2.1	1.9	1.8	1.7	1.6	1.5
MVM22TA-VA1	3.0	2.8	2.6	2.5	2.4	2.2
MVM28TA-VA1	3.7	3.5	3.2	3.1	2.9	2.7
MVM36TA-VA1	4.7	4.3	4.0	3.8	3.7	3.3
MVM45TA-VA1	5.8	5.4	5.0	4.8	4.6	4.1
MVM56TA-VA1	7.3	6.8	6.3	6.0	5.8	5.3
MVM71TA-VA1	9.3	8.6	8.0	7.7	7.4	6.7

Abbreviations:

TC: Total capacity (kW)

Notes:

1. Shaded cells indicate rating condition

8 Electrical Characteristics

Table 8.1: Arc series duct electrical characteristics

Model name	Power supply						Indoor fan motors	
	Hz	Volts	Min. volts	Max. volts	MCA	MFA	Rated motor output (W)	FLA
MVM15TA-VA1	50/60	220-240	198	264	0.36	15A	20	0.29
MVM22TA-VA1	50/60	220-240	198	264	0.40	15A	20	0.32
MVM28TA-VA1	50/60	220-240	198	264	0.46	15A	20	0.37
MVM36TA-VA1	50/60	220-240	198	264	0.55	15A	20	0.44
MVM45TA-VA1	50/60	220-240	198	264	0.86	15A	30	0.69
MVM56TA-VA1	50/60	220-240	198	264	0.95	15A	30	0.76
MVM71TA-VA1	50/60	220-240	198	264	1.11	15A	30	0.89

Abbreviations:

MCA: Minimum Circuit Amps

MFA: Maximum Fuse Amps

FLA: Full Load Amps

9 Sound Levels

9.1 Overall

Table 9.1: Arc series duct sound pressure levels¹

Model name	Sound pressure levels dB(M)						
	SSH	SH	H	M	L	SL	SSL
MVM15TA-VA1	27	25.5	24	23	22	21	20
MVM22TA-VA1	28	27	26	25	24	23	22
MVM28TA-VA1	30	29	28	27	26	25	24
MVM36TA-VA1	30	29	28	27	26	25.5	25
MVM45TA-VA1	34	33	32	30	29	28	26
MVM56TA-VA1	36	34	33	32	31	30	28
MVM71TA-VA1	37	35	34	32.5	31	30	29

Notes:

1. Sound pressure levels are measured 1.4m below the unit in a semi-anechoic chamber. During in-situ operation, sound pressure levels may be higher as a result of ambient noise.

Figure 9.1: Arc series duct sound pressure level measurement

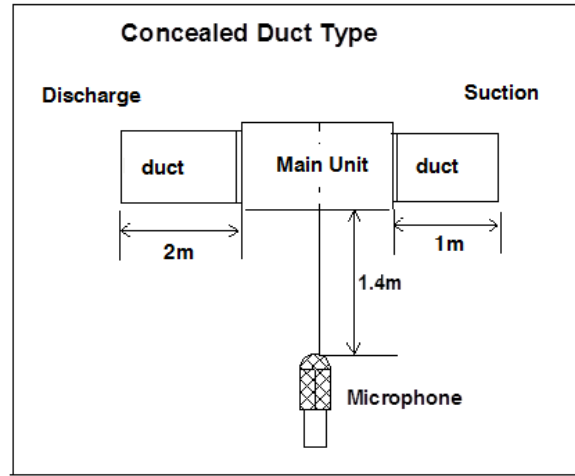

9.2 Octave Band Levels

Figure 9.2: MVM15TA-VA1 octave band levels

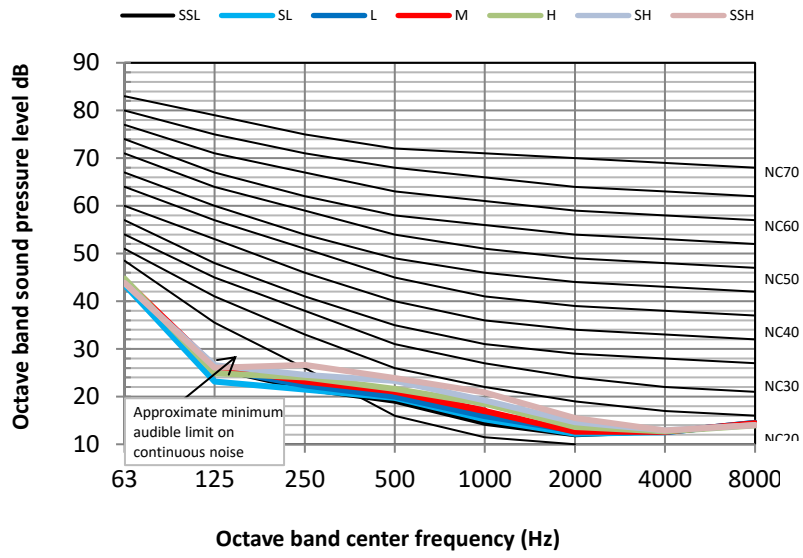
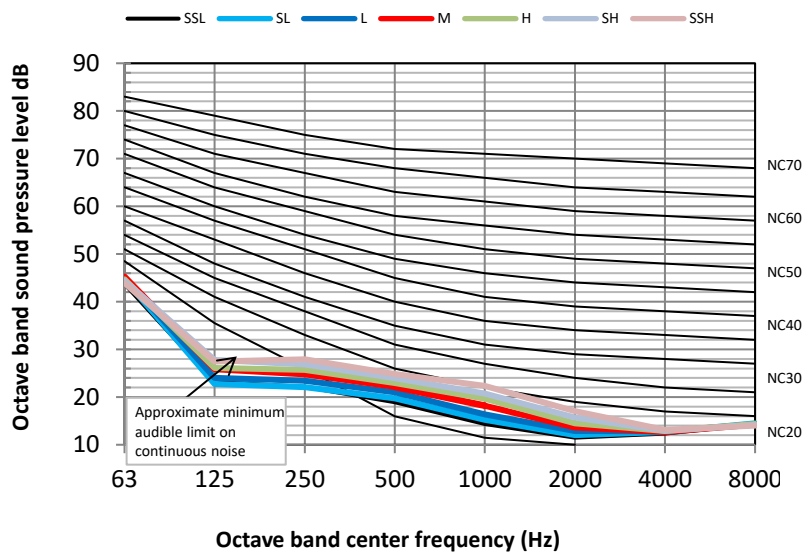

Figure 9.3: MVM22TA-VA1 octave band levels



New Atom VRF IDU Arc Series Duct



Figure 9.4: MVM28TA-VA1 octave band levels

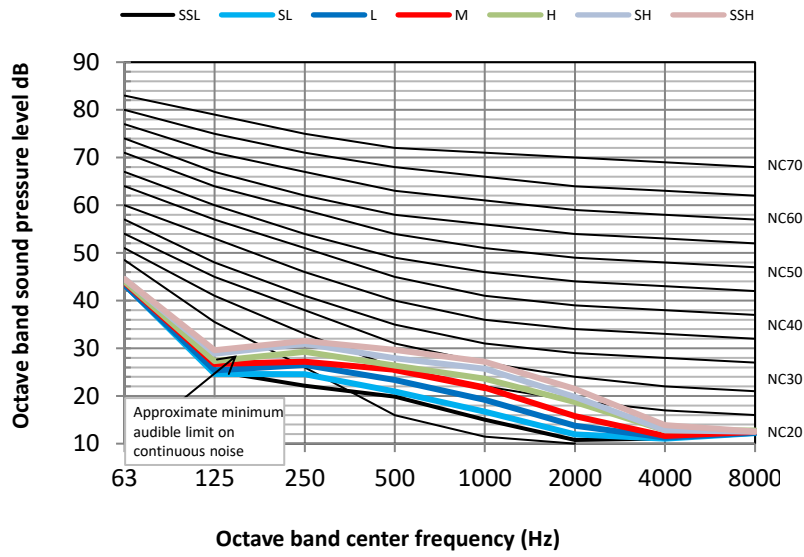

Figure 9.5: MVM36TA-VA1 octave band levels

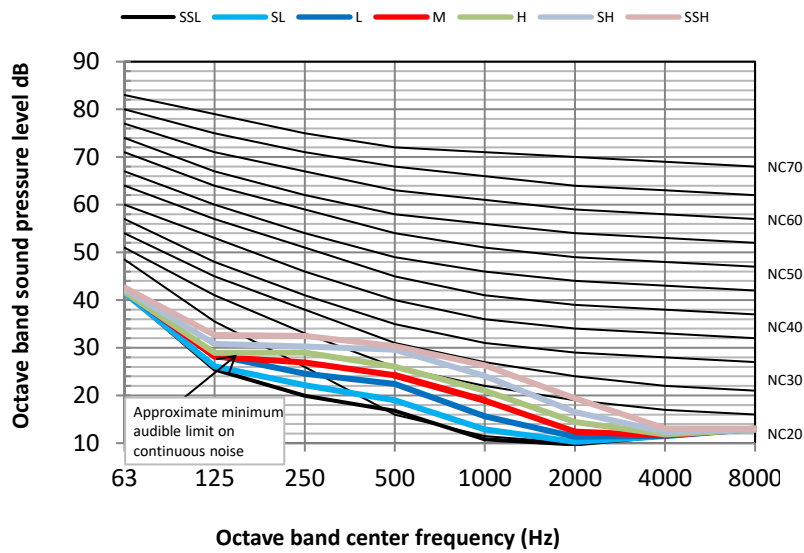

Figure 9.6: MVM45TA-VA1 octave band levels

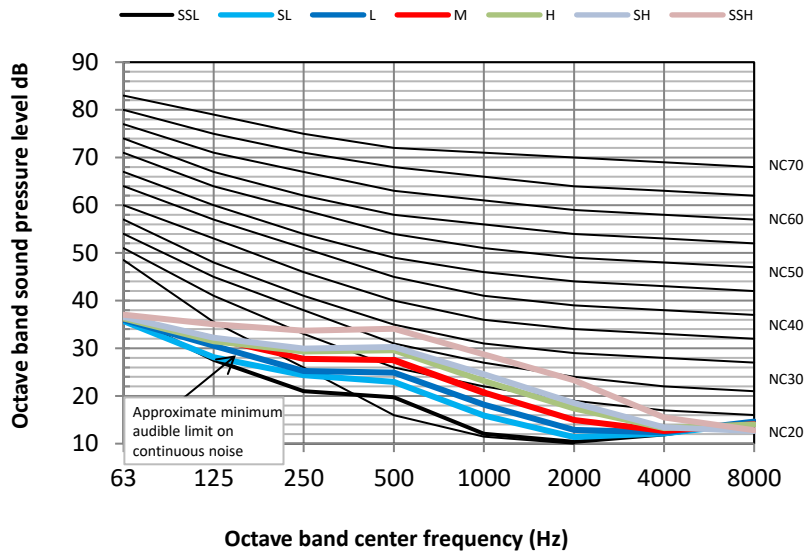
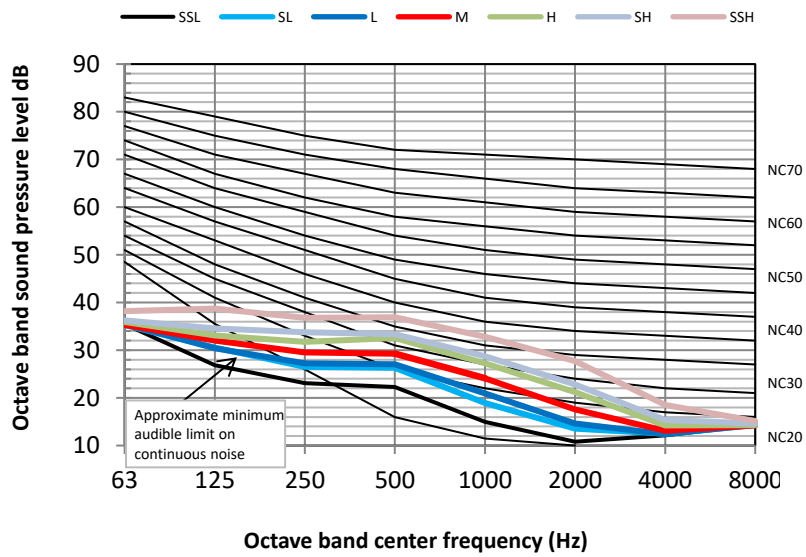

Figure 9.7: MVM56TA-VA1) octave band levels



New Atom VRF IDU Arc Series Duct



Figure 9.8: MVM71TA-VA1 octave band levels

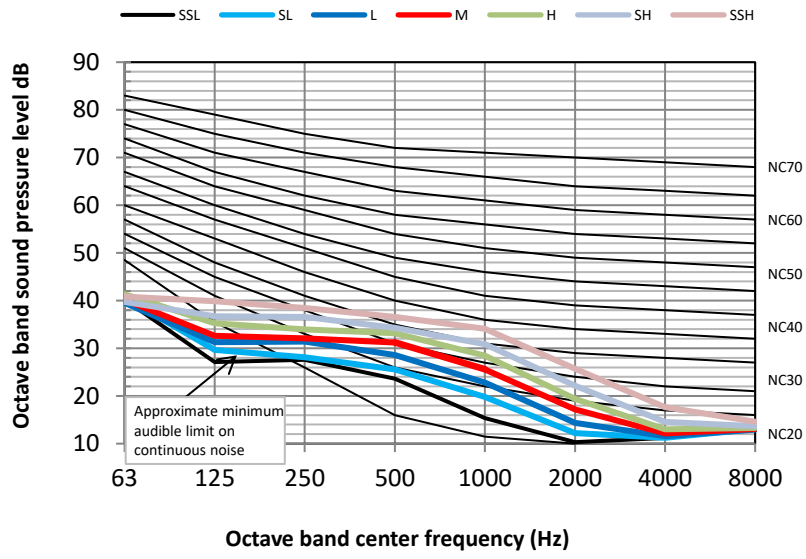

Midea Building Technologies Division
Midea Group

Add.: Midea Headquarters Building, 6 Midea Avenue, Shunde, Foshan, Guangdong, China

Postal code: 528311

mbt.midea.com / global.midea.com

Note: Product specifications change from time to time as product improvements and developments are released and may vary from those in this document.

